

Technical Proposal
Personal Rapid Transit System Design

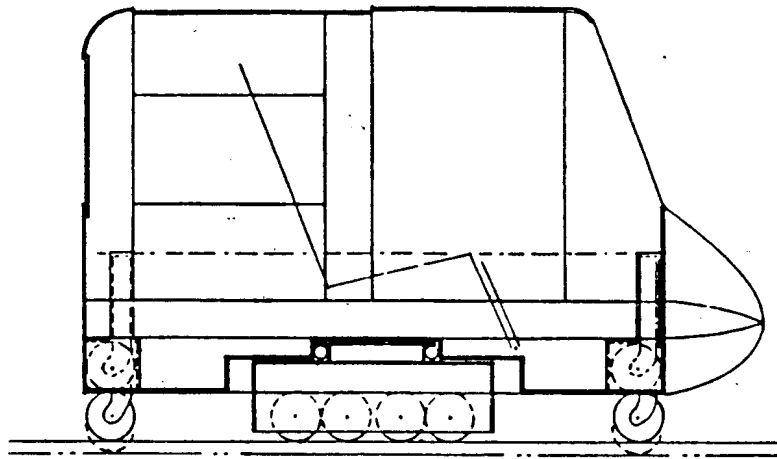

August 3, 1990

Kolbjorn Saether and Associates, Inc.
Registered Structural Engineers

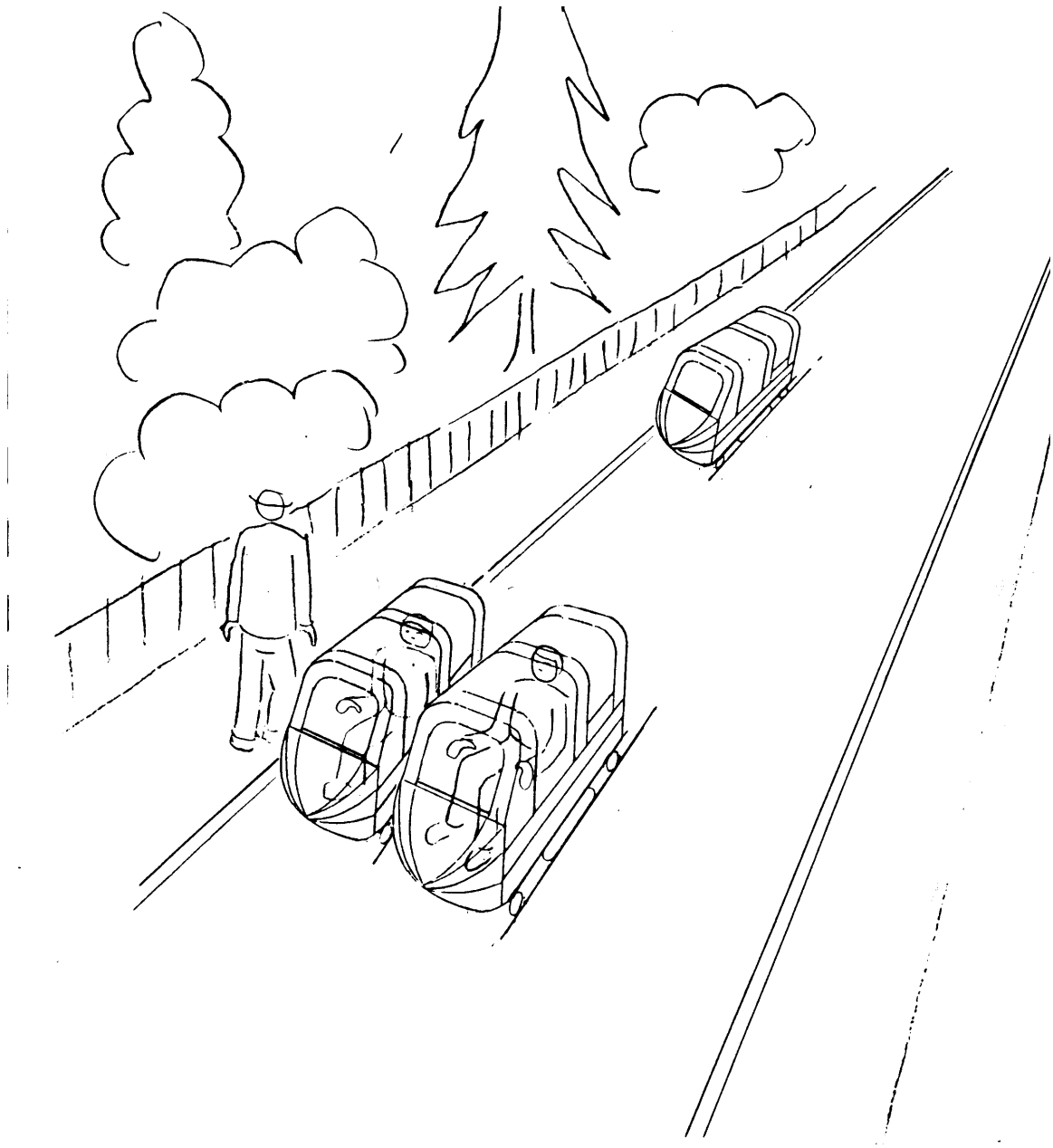

PTM ON SELECTED LOCAL STREETS

(V = 20 MPH)

(V = 5MPH)

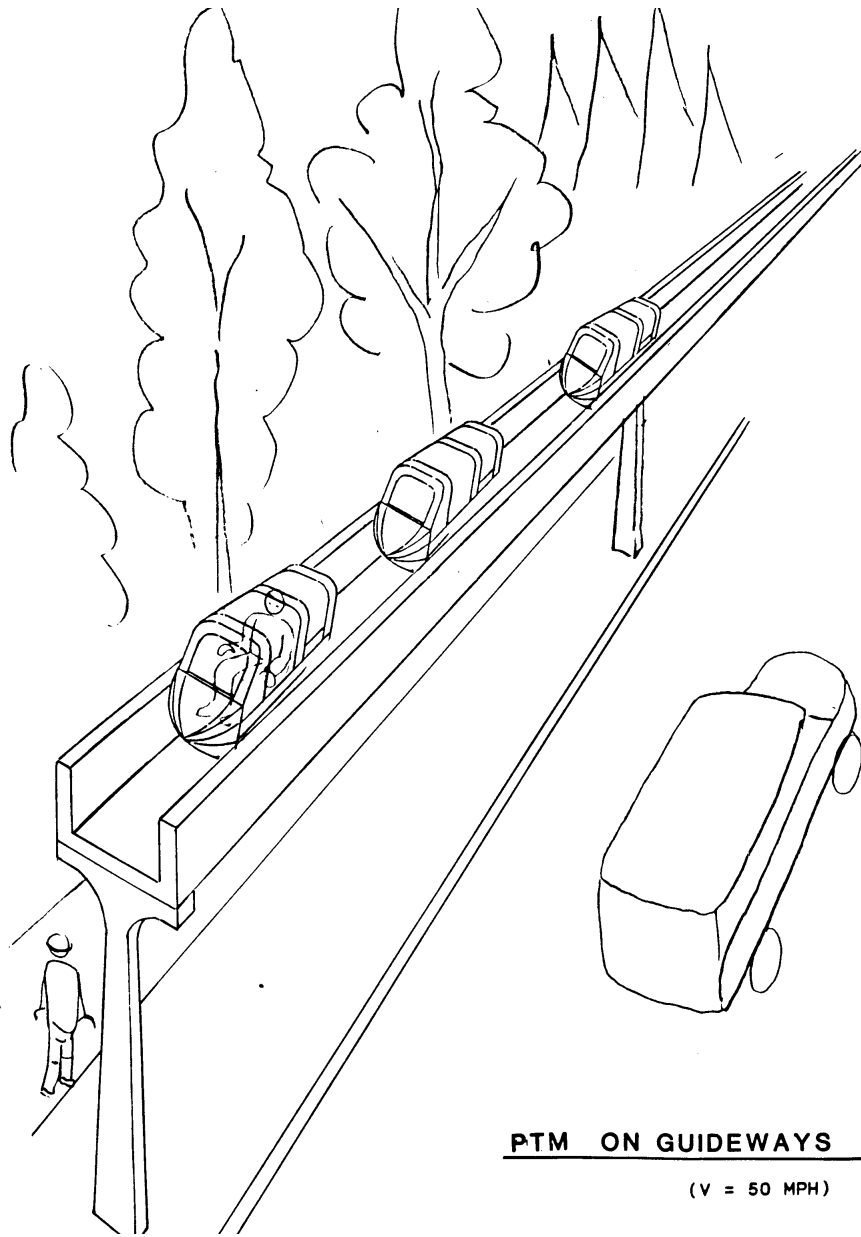

PTM ON GUIDEWAYS

(V = 50 MPH)

Table of Contents

- Task 1 PRT System Design..... 1
 - The Module..... 2
 - The Guideway..... 13
 - The Station..... 22
 - Normal Travel Sequence 30
 - Entry Sequence..... 31
 - Exit Control..... 34
 - Accident Control 34
- Task 2 Site Specific Design 38
- Task 3 Urban Design..... 39
- Task 4 Simulation 40
- Task 5 Communication with Public, Mockups/Models 41
- Task 6 Public Presentation Report..... 42
- Task 7 System Development and Deployment Planning..... 43
- Task 8 Planning 44
 - Appendix 45

Section 3.0

Phase I: Scope of Work

Task 1 PRT System Design

3.1.1 System Design: Basic Philosophy

Our primary goal is to create a Personal Rapid Transit System that has the ability to parallel or exceed the luxury and convenience of the contemporary automobile. We believe that such a system will be socially and financially viable only if it is part of a complete solution to the transportation problem. The system presented here fulfills these requirements.

Our design initially targets two items: an improved vehicle and simplified roadway. In Appendix A, we show how our system may one day fuse with the existing transportation methods, easing the negative impact of transportation systems as a whole.

Our solution is to build a humanized, all-purpose, personalized component, "The Transportation Module." Propelled by an independent, dual-belted tractor, the module has overland travel capability. This battery-operated tractor also allows the module to access the guideways on entrance and exit ramps.

The guideways are pre-cast concrete roadways. They may be constructed in existing suburban areas with minimum inconvenience and cost. A linear electro-magnetic motor is specified to be located in its side rails. It will guide and propel the transportation modules. A computerized system of inducers and sensors monitors the speed and spacing of the modules. An onboard computer activates a solenoid switch to cause the modules to enter and leave the guideway system.

Today's technology has made it possible for a traveler to stay in contact with the outside world while on the road. Our development of automation and modification of conventional travel (see Appendix A) allows the traveler to make full use of this technology, while permitting complete relaxation throughout the trip.

3.1.2 Operating System Elements

Our complete solution to the public rapid transit system will eventually consist of modifying many components, such as trucks, railroad cars, and airplanes. However, only

two components are dealt with in this proposal: "The Module" and "The Guideway." The complete solution is shown in the appendix to this presentation.

The Module

The module is composed of "The Vehicle" (Figures 1 through 7) and "The Tractor" (bogie) (Figures 8 and 9). "The Vehicle" is rigidly modular and owned either by the transit Authorities or by individual persons. The "Tractor" is similarly owned privately or by the Transit Authorities.

The tractor is an assembly of four rechargeable batteries and two motor driven belts. The motors are capable of full traction at various speeds from zero to maximum, both forward and reverse. The motors are fully weather-enclosed, located in the heart of the belt, and capable of being fully submerged in water. The tractor is hooked onto the module using a cylindrical enclosure and a soft gasket. It is capable of rotating ninety degrees left and right with respect to the module, and is held in each position with a quick release connection. When engaged, the controls of the capsule are automatically connected to this unit. The rubber gasket prevents the jerking movements of the tractor from being transmitted into the vehicle itself. The maximum speed of this tractor is 30 mph.

The batteries operate for 24 hours between charges. The battery pack is the only energy source for the module. It also supplies power for an air compressor located within the vehicle. The compressed air operates several sub-components within the vehicle.

The tractor measures 2'6" by 2'6" and stands 8" high, including an extension into the underside of the vehicle. The technology for creating the tractor unit is obtained from overland vehicles with caterpillar tracks, such as farm tractors and snowmobiles.

The tractor provides the vehicle with low speed propulsion and steering while traveling on sidewalks or designated local streets, as well as while moving around the RTA station and parking lot. It also provides propulsion for accessing the guideway, using the entrance ramps, and braking for the module on the exit ramp.

The vehicle is 6' long and 3' wide. Sitting on top of the tractor, its maximum height above ground is 4'6". The unit contains four casters. These are held in vertically placed pneumatic spring-loaded cylinders. These cylinders are activated by air pressure and will raise or lower the casters. The vehicle is either supported by the four casters, by the tractor, or in combination. When supported by the casters only, the tractor is suspended underneath the vehicle.

The vehicle contains one main seat that may recline to a sleeping couch. A small panel controls all movements of the module. The forward one third of the vehicle's side panels and roof form a clear plastic U-shaped double door. The door slides back to allow exit from the vehicle. It also allows the passenger to stand while underway at slow speeds. The back

panel of the vehicle and the last one third of the side panels have windows that will retract into the fixed bottom half. All panels are one-way translucent plexiglass and will furnish full privacy within the vehicle, while rendering complete visibility to all sides. A typical vehicle may be outfitted with a baby crib and two junior seats. A slight modification of the rear panel of the vehicle will allow this to fold down, forming an access ramp for wheelchairs.

The vehicle with the tractor is capable of traveling under its own power at speeds up to 20 mph on the roads, and a maximum speed of 30 mph in the acceleration lanes of the guideway. Once it is on the main guideway, it will travel at a speed of 50 mph, propelled by electro-magnetic linear motors. On the guideway, its operation is fully automated. On the ground, it is operated by the traveler.

At the low speed of 5 mph, it is designed to travel the neighborhoods by utilizing sidewalks with curb cuts for wheelchairs. On selected neighborhood streets the module may be operated at 20 mph. The maximum module speed of 30 mph is used only at entrance and exit ramps to the guideway system.

The module allows travel from home to guideway, and from exit station to point of destination in addition to guideway travel. When parked, it occupies 1/3 to 1/6 of the space necessary to park a passenger car. Batteries may be recharged in most parking areas.

For traveling on the guideways, the module is furnished with permanent magnets that interact with electro-magnets built into the guideway side rails. It further contains sensors interacting with stationary computerized checkpoints along the guideway for the individual control of the modules.

When on the road, in addition to the forward and reverse movements, the module may move laterally. In either position the module is propelled and steered by the double belts.

Modules owned by RTA would be equipped without luxury items. They will have plain seats with no special amenities within the vehicle. If the leaving the guideway area, these modules are rented out by the authorities on a per trip basis, on an extended rentals for a day, week or month.

The privately owned modules are owned inclusive or exclusive of the tractor. The tractor can be rented separately from the Transportation Authorities. These privately owned modules may contain any type of equipment. Its interaction to the outside, however, follows firm outlines. To be used on the guideways, modules must comply with the norms formulated for the module concept. No modification of this outline is permitted. The module is driven through a computerized checkpoint to verify this compliance each time it enters the guideway system.

The interior of the vehicle, on the other hand, shows no restrictions beyond those induced by the size of the module. The vehicle is sized to accommodate a person up to 6'8",

weighing up to 250 pounds. The seat and interior equipment can be as luxurious as the owner desires. Equipment may include telephones, computers, televisions, and stereo systems. Retractable tables and reading lights may be included.

The module may travel outside of the guideway system singly or in combined units. A single module would assume control for the group. While traveling in groups, the windows may be rolled down to allow conversations between the occupants in the individual modules. In connecting several units, the pneumatic support system is interconnected to equalize the support of the various modules.

In the first phase, the modules travel on sidewalks at maximum speeds of 5 mph, utilizing curb cuts to get from one sidewalk to the other. Travel is limited to the neighborhood, allowing a person to get to and from school, stores, and other local places fully protected against weather conditions and safe from intrusion by outsiders. The strength of the module enclosure and the alarm systems within the module provide safety for occupants.

As the number of modules increases, villages or cities may elect to assign certain streets to be used by both modules and automobiles. The speed limit on these streets would be restricted to 20 mph.

Figure 1

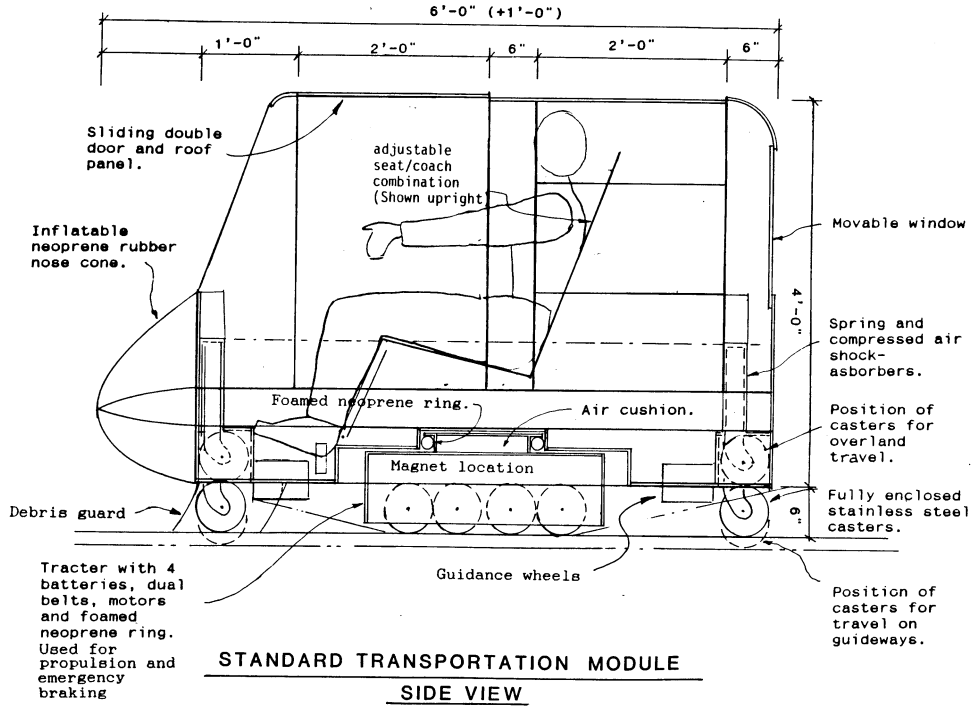

F

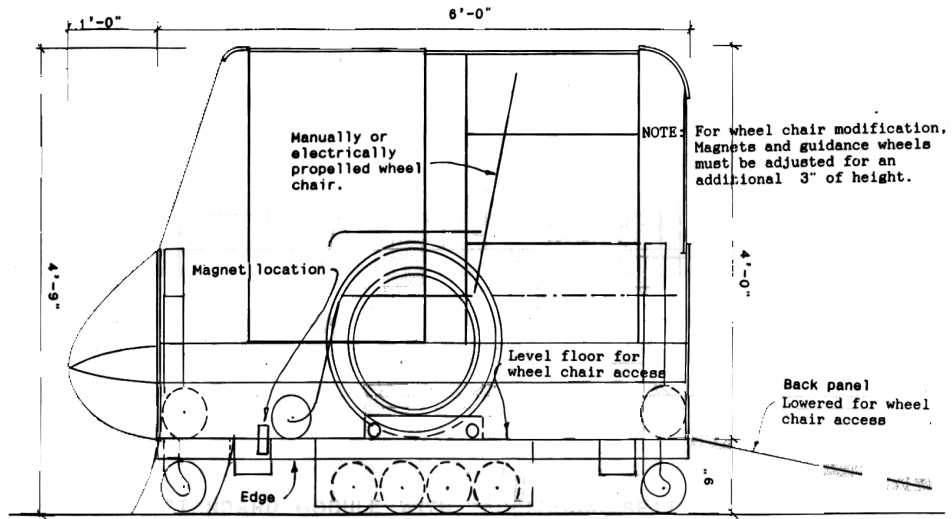

**TRANSPORTATION MODULE MODIFIED
FOR WHEEL CHAIRS**

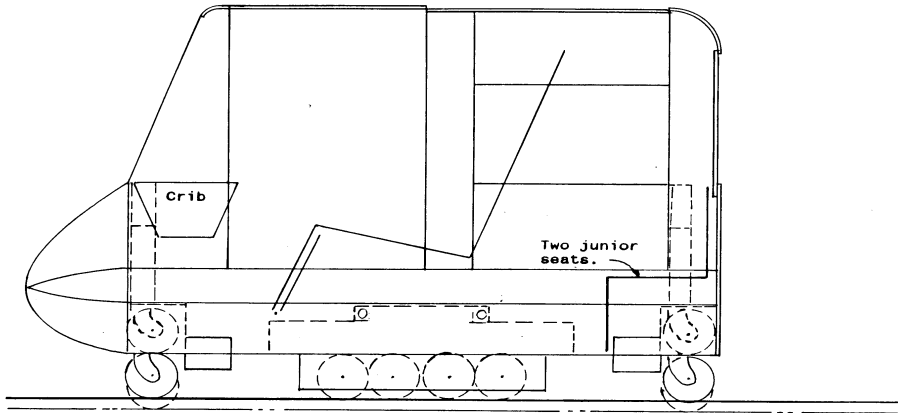

STANDARD MODULE WITH ADDITIONAL SEATING

SCALE: 1" = 1'-0"

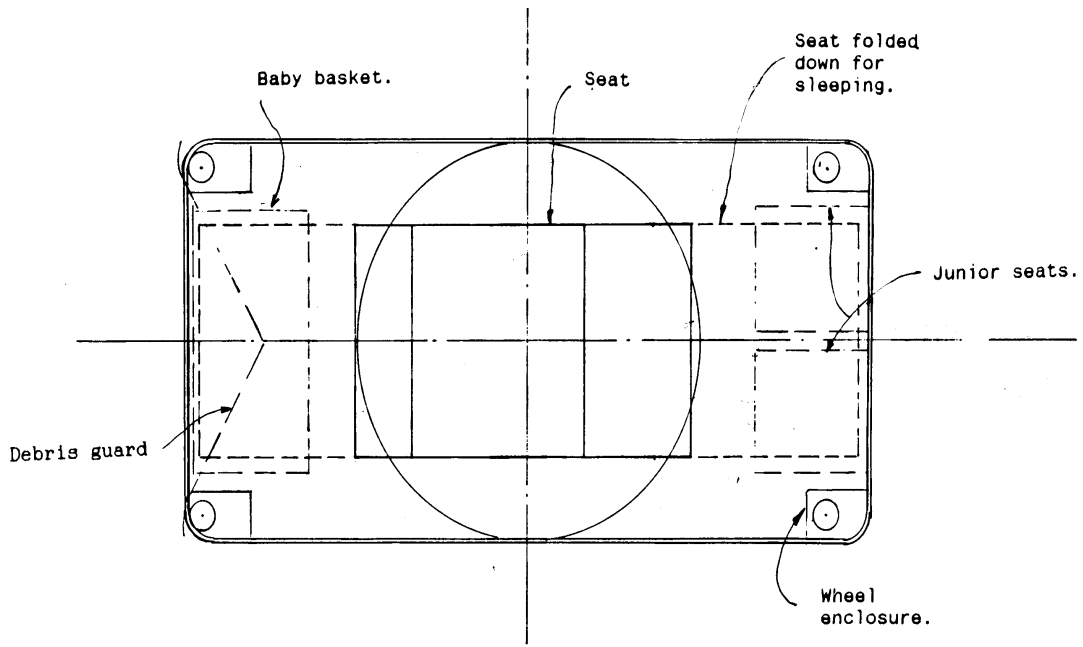

STANDARD TRANSPORTATION MODULE
PLAN VIEW

Front View

Rear View

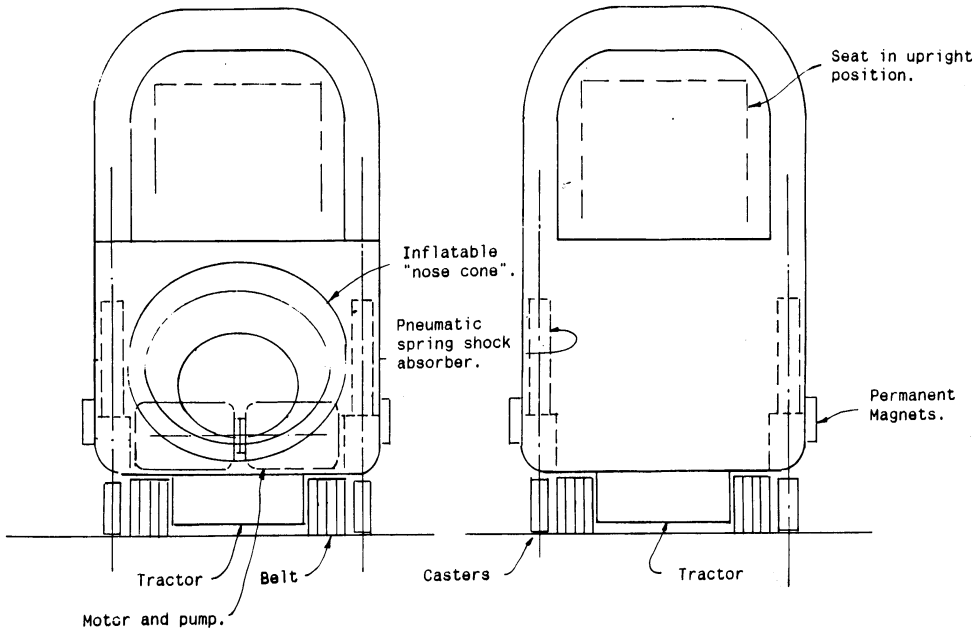

STANDARD TRANSPORTATION MODULE

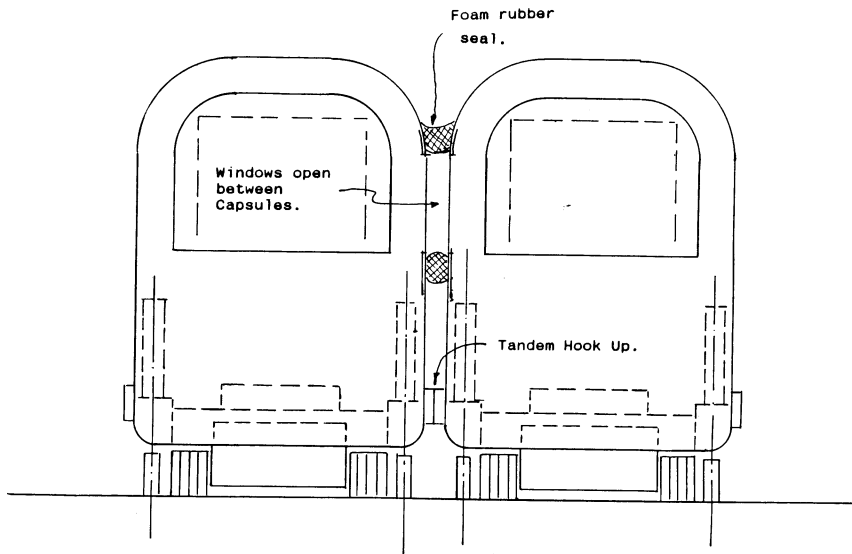

STANDARD TRANSPORTATION MODULES
COUPLED FOR OVERLAND TRAVEL

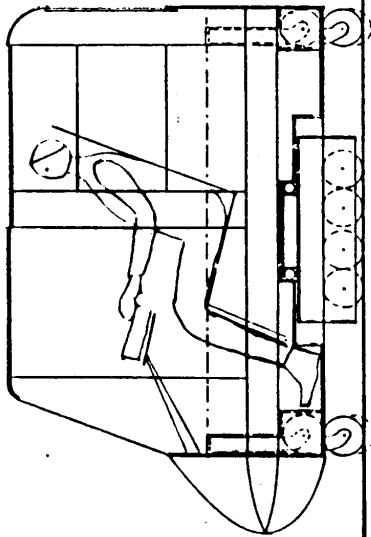

Reading, writing,
working computer.

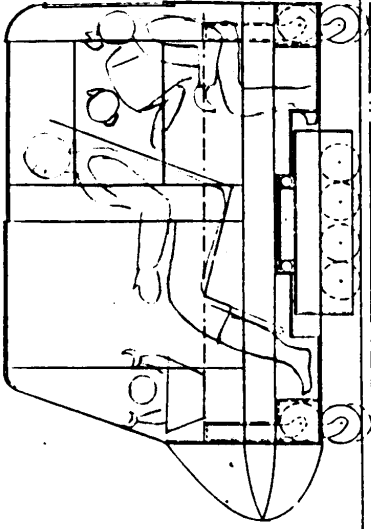

Travelling with
small children.

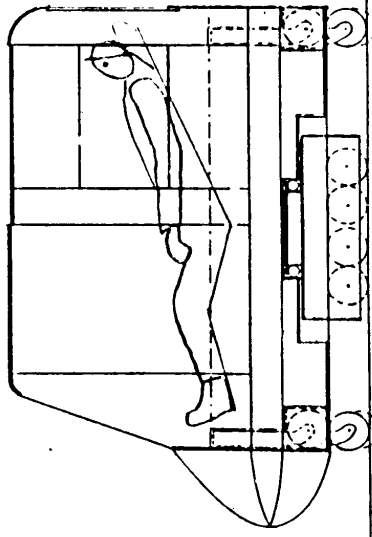

Sleeping or
watching TV.

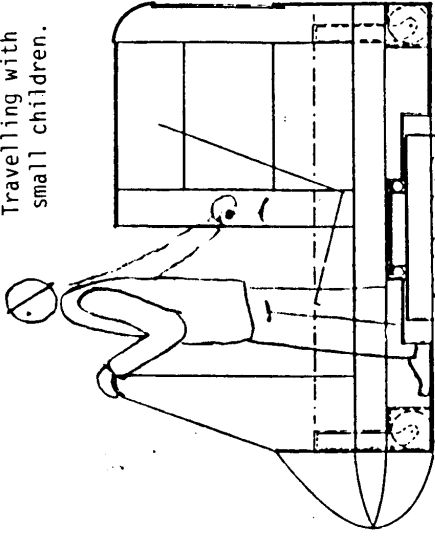

Overland
sightseeing.

STANDARD PTM - VARIOUS USES

SCALE: 1/2" = 1'-0"

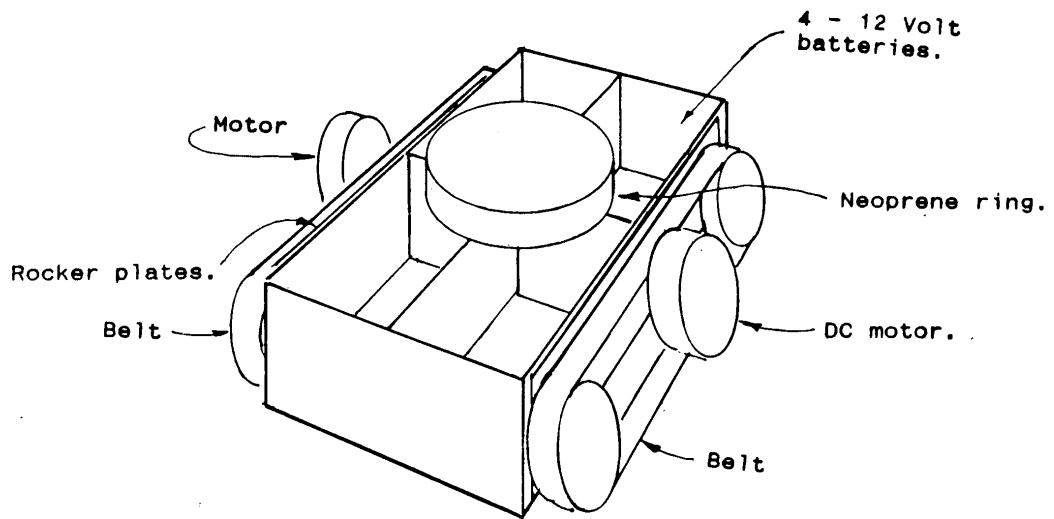

TRACTOR (ISOMETRIC)
NO SCALE

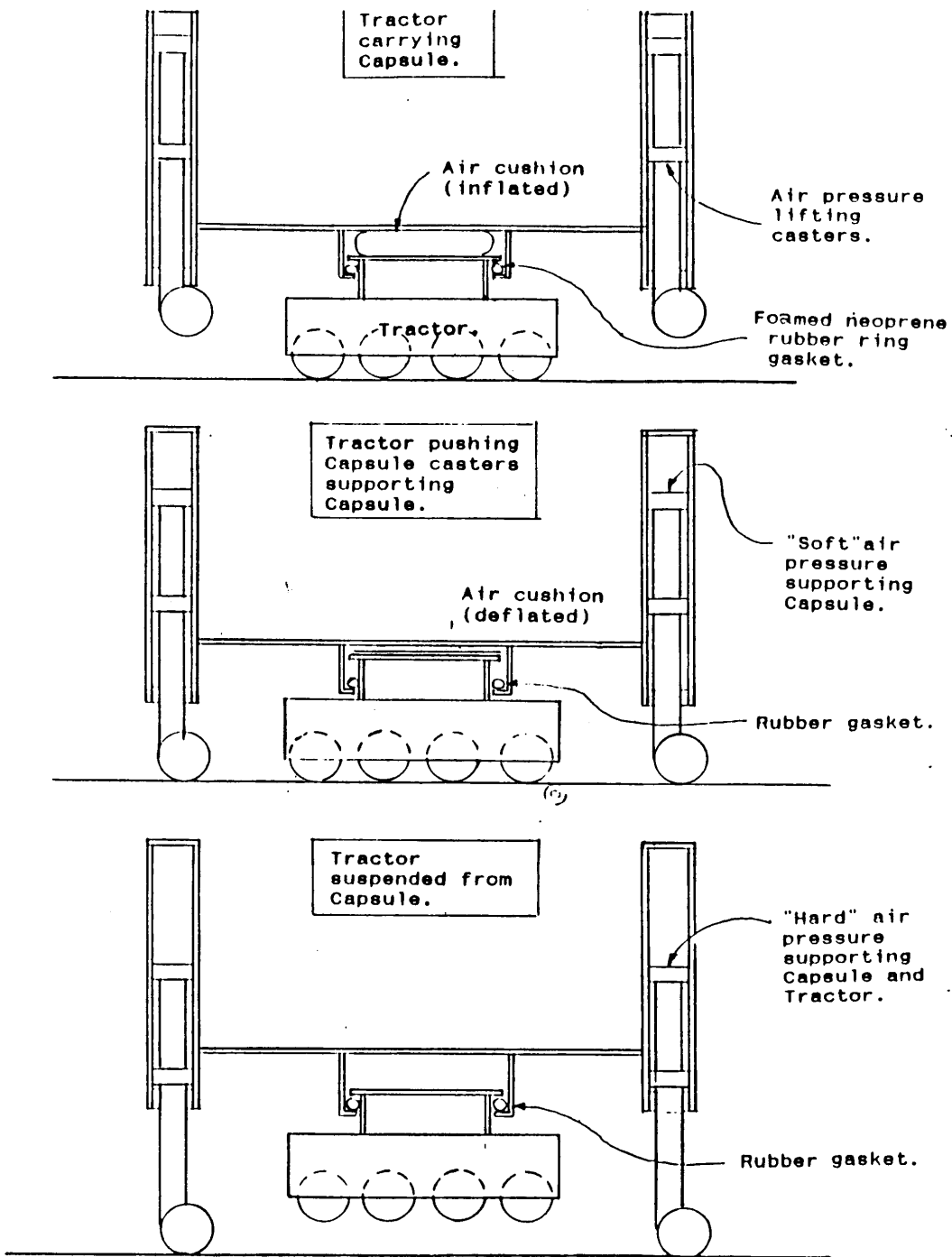

**SCHEMATIC INTERACTION BETWEEN
CASTER/CYLINDER COMBINATION AND TRACTOR**

The Guideway

The next phase in use of the module is the introduction of guideways. These are elevated tracks that connect one suburb to the next, and are placed where no expressways are available. The guideway is a single elevated 'expressway' built to furnish large capacity transportation into the neighborhood for minimum cost and minimum interference to the existing neighborhood.

The design of the guideway system will entail the study of the areas that the guideway will serve. Traffic history and the projected travel volume will be obtained from the Transportation Authorities. A layout will be prepared showing the guideway, and the desired station locations. All of the planning will be done in cooperation with the RTA and under their guidance.

Next, a check will be made of the specified headway required to assure that this will furnish the required traffic capacity as specified by RTA. The lineage will be checked for neighborhood impact. Alternative routes will be studied in a effort to minimize the negative effects of the guideway.

Guideways are 5'6" wide, 3'0" high, single direction tracks. They are placed at the height of street lights or above. The guideways are supported on single pylons, spaced at 60', and consist of pre-cast concrete U-shaped beams. They have individual lanes for acceleration and deceleration, and ramps for access or egress. Inspection facilities are located at the base of the entrance to clear the module for travel on the guideway.

The power required for climbing the entrance ramps and for reducing the speed at exits is furnished by the battery-operated tractor. Once on the guideway, the tractor is suspended from the module (Figure 9). The propulsion of the module is replaced by an electro-magnetic system that will guide and propel the module at speeds of 50 mph. The basic principle of this electro-magnetic linear motor is shown in Figure 23. It may be purchased as an existing system or as existing components. The modules travel in continuous rows, but completely disengaged from one another (Figures 11 through 14). Spacing is controlled by modification of the magnetic impulses that each module receives. Space is similarly provided as a module appears on the entrance ramp for induction into a row of modules. At the exit ramp, the module is subjected to electro-magnetic control through a mechanical switch (Figure 19), which diverts subsequent modules onto alternating exit ramps for deceleration. Once stopped, the module will use the tractor to proceed under its own power.

The cost of various layouts will depend on ownership and land cost. Sharp curves and abrupt elevation changes will be minimized. The layout will be optimized to give the lowest cost and the best riding characteristics. It will be checked for potentially dangerous obstructions such as large trees or other components that can impose hazards to the guideway.

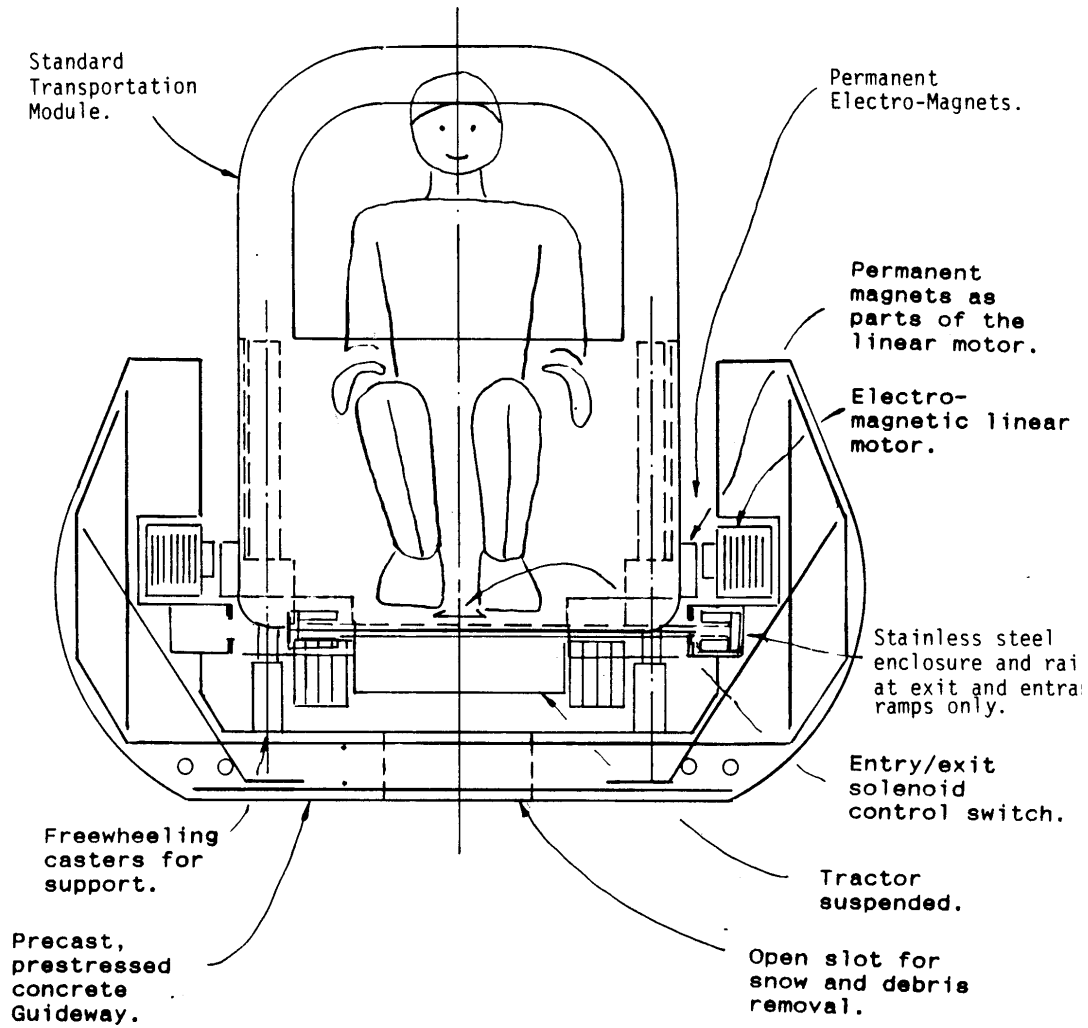

TYPICAL SECTION THROUGH GUIDEWAY

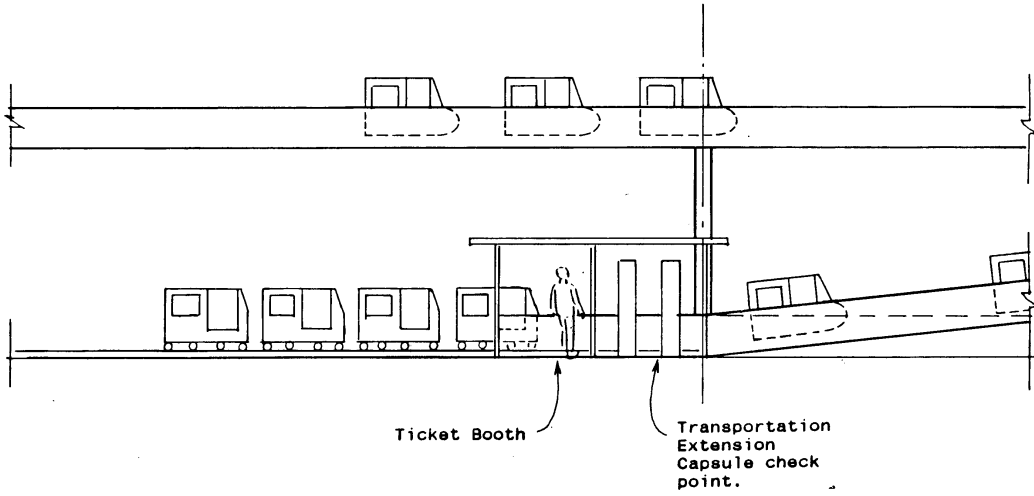

TYPICAL ENTRY RAMP

SCALE: 1/8" = 1'-0"

Figure 12

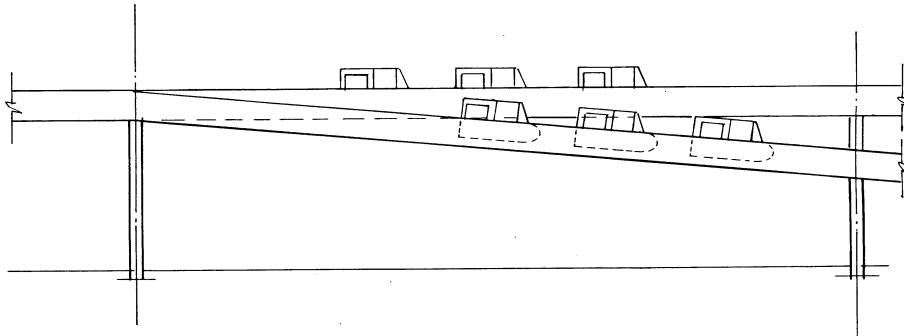

TYPICAL EXIT RAMP (TOP HALF)

F

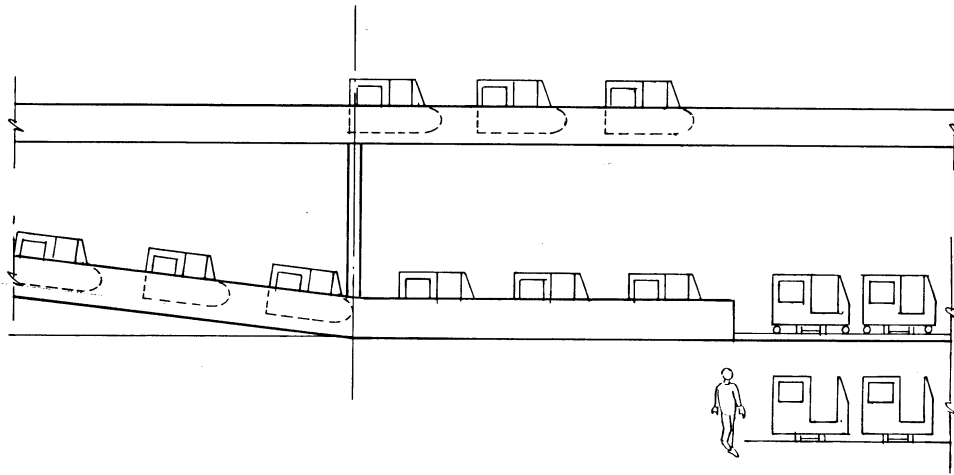

TYPICAL EXIT RAMP (BOTTOM HALF)

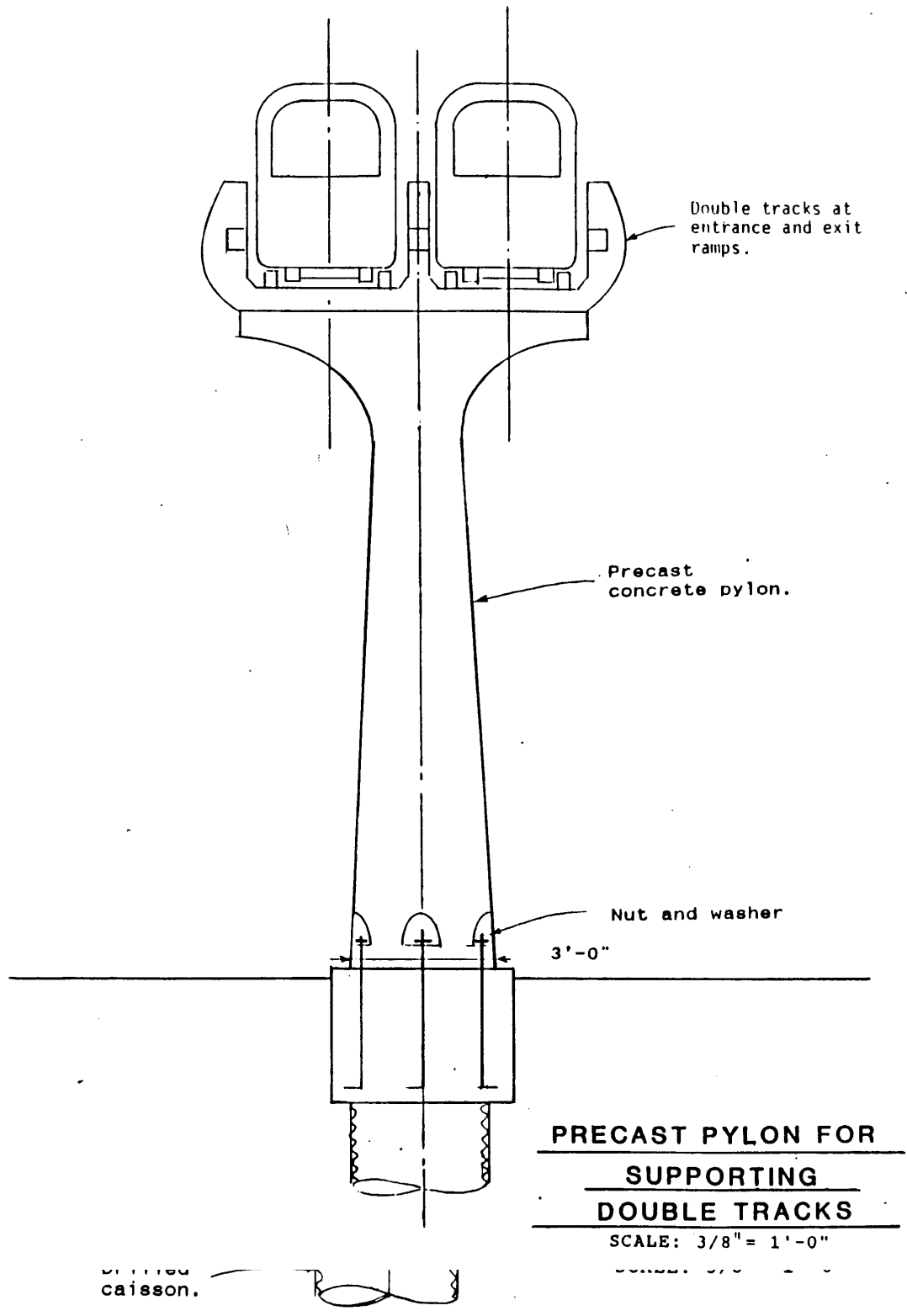

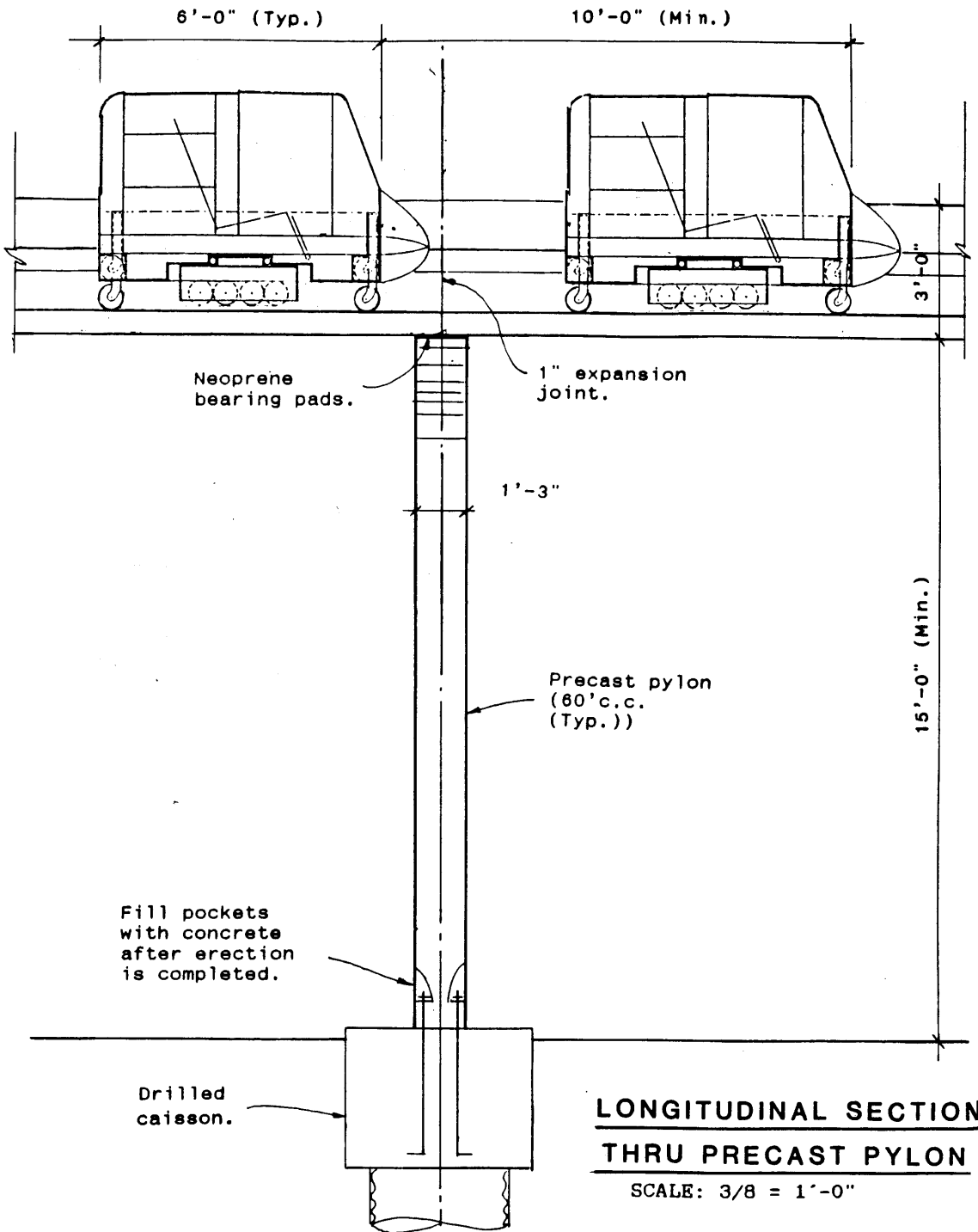

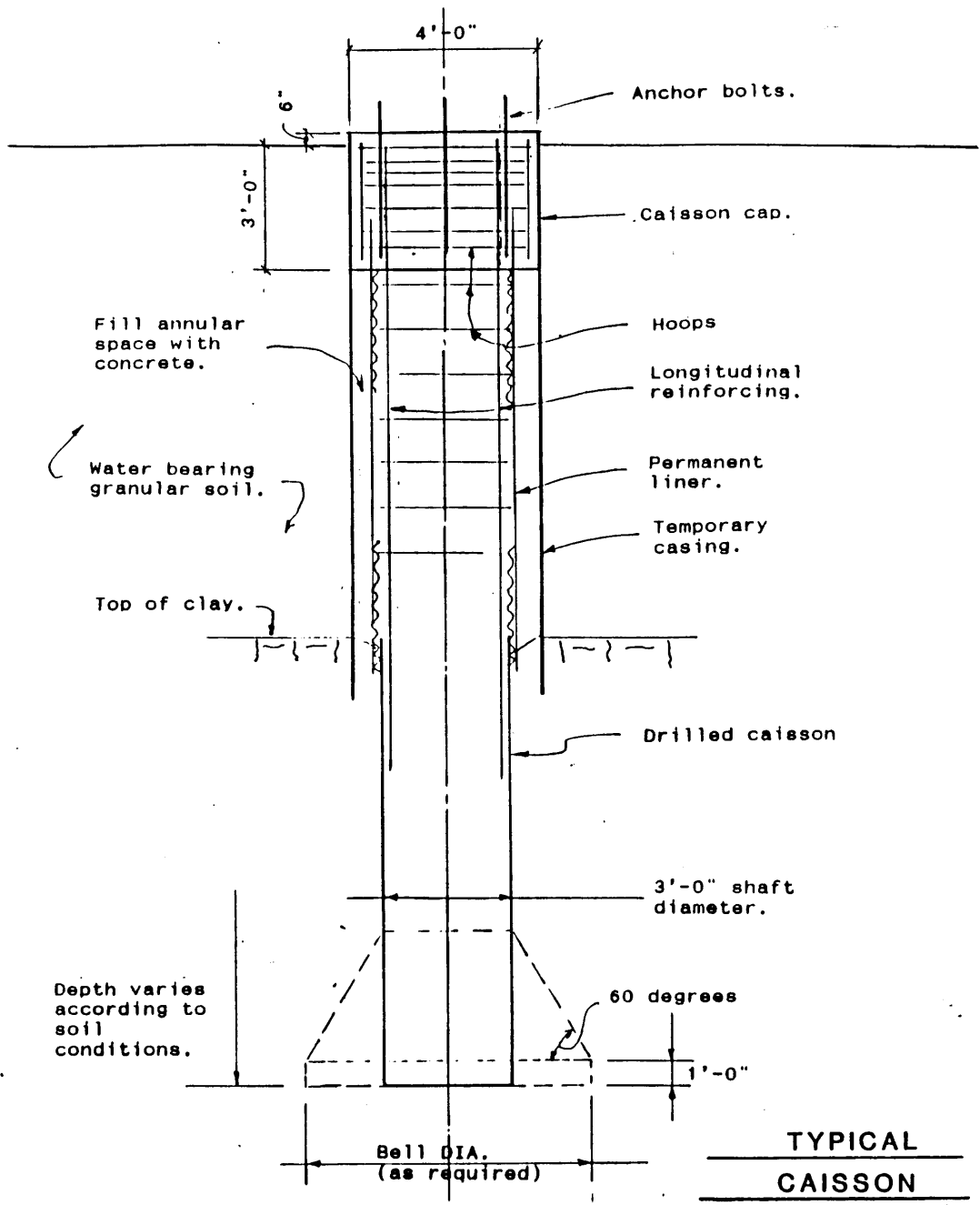

**TYPICAL
CAISSON
FOUNDATION**

SCALE: 3/8" = 1'-0"

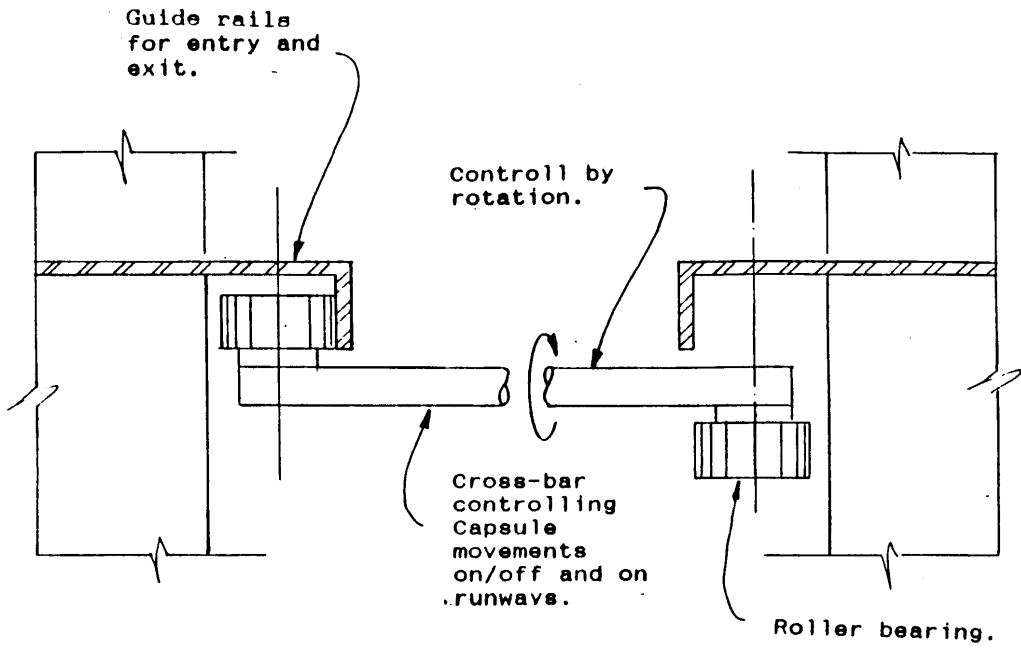

GUIDE RAIL LANE SWITCH.

(No scale)

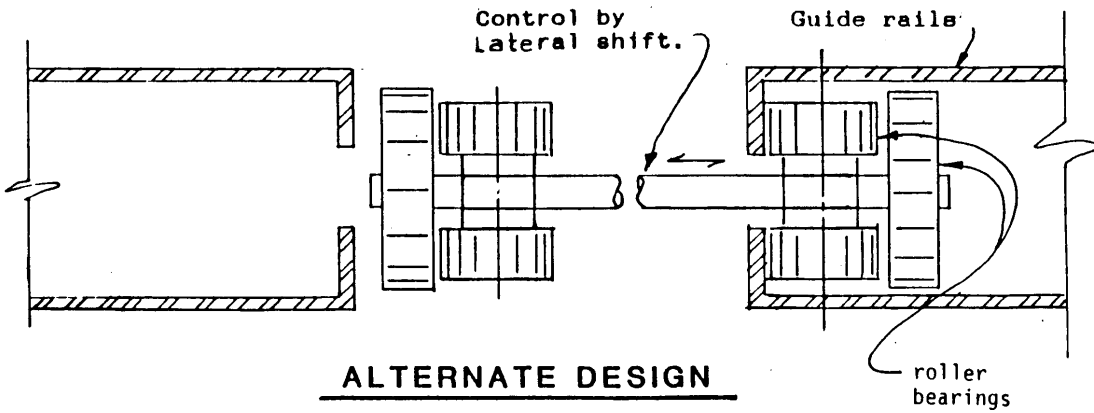

ALTERNATE DESIGN

The Station

All stations contain exit and entrance ramps, service and storage/recharge (buildings) facilities, computerized checkpoints, and toll gates. For each guideway location, one administration building and some major repair shops are provided.

Before entering the guideway, the module passes through a computerized checkpoint to confirm that all systems are in working order. If the module fails the test, it is automatically rerouted for repair.

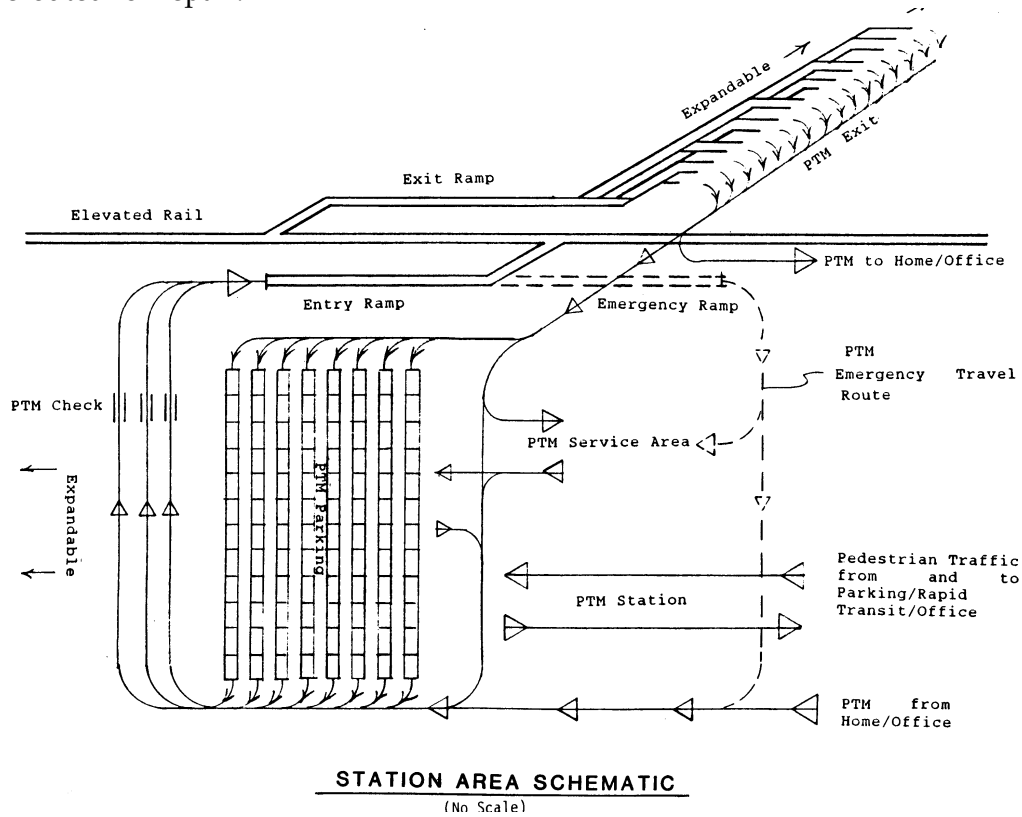

3.1.3 Subsystems

At guideway stations, a computer will monitor the need for RTA-owned modules, and will automatically dispatch empty modules to appropriate stations. The computer will monitor the influx of privately owned modules using the guideways, and will separate these from the RTA owned units at the destination point.

3.1.4 Failure Modes and Effect Analysis

The philosophy behind the module design is a dual support and propulsion system. Should, for example, one of the casters malfunction, the tractor will propel the module to an exit ramp, and repair facility. If, for some reason, the propulsion system is ineffective for any one module, the module that follows will push the disabled module to an exit ramp where the tractor will furnish the propulsion.

Recharging of batteries is done at the terminal or at the terminal or at the home, wherever the module is stored. Typical RTA Maintenance facilities will be furnished with battery recharge capabilities and the ability to repair casters, tractor motors and other module components.

Effects Analysis for Driving on the Guideway (Figures 21 through 26)

GUIDE CONTROL:	Opposing fixed and electromagnets
SPEED CONTROL:	Computer controlled energy input
SPACING CONTROL:	Computer controlled energy input
ACCELERATION CONTROL:	Computer controlled energy input
MERGING CONTROL:	Computer controlled energy input
EXIT CONTROL:	Mechanical switch. Electro-magnetically activated, computer monitored
ACCIDENT CONTROL:	Danger signal through sensor
LOAD CONTROL:	Computer controlled energy input

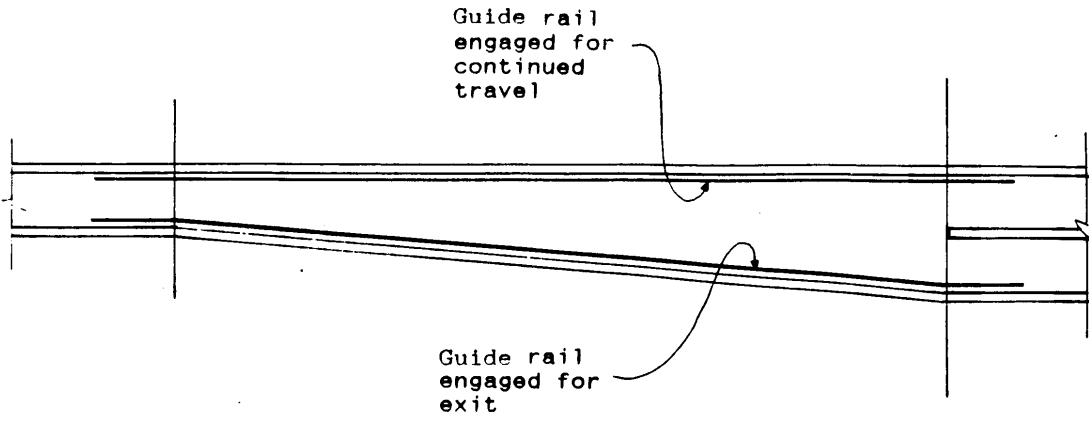

SCHEMATIC PLAN OF EXIT RAMP

Scale = 1/8" = 1'-0"

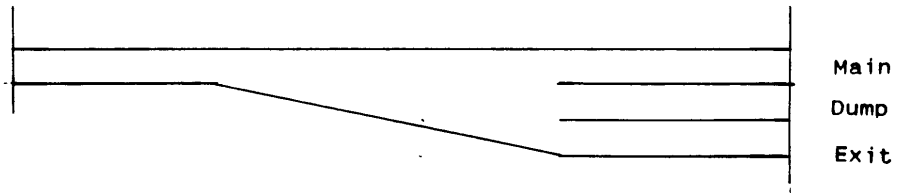

Add a "Dump" lane

ALTERNATE LAYOUT

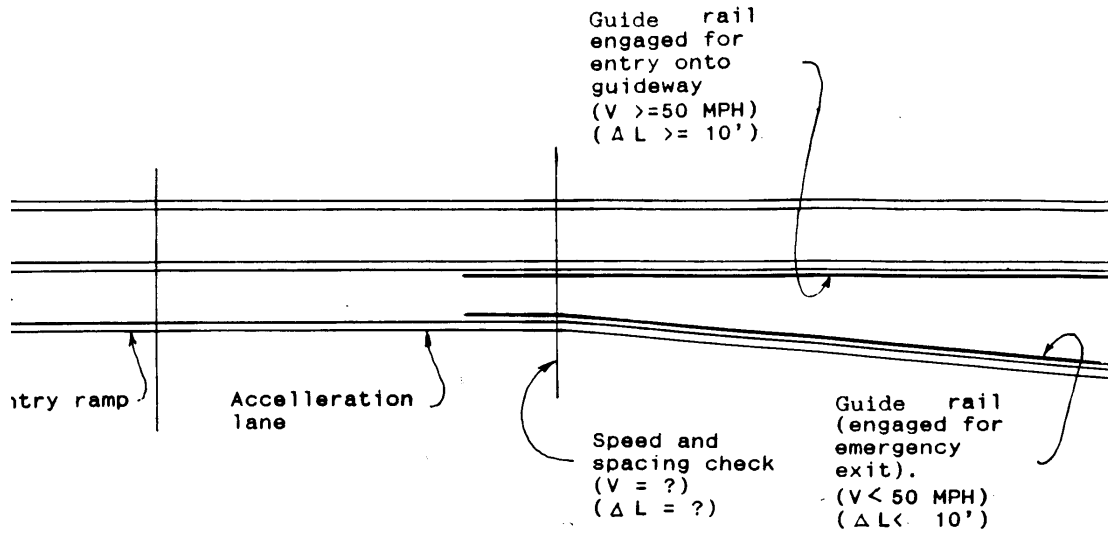

SCHEMATIC PLAN OF ACCESS RAMP (LEFT HALF)

Scale: 1/8" = 1'-0"

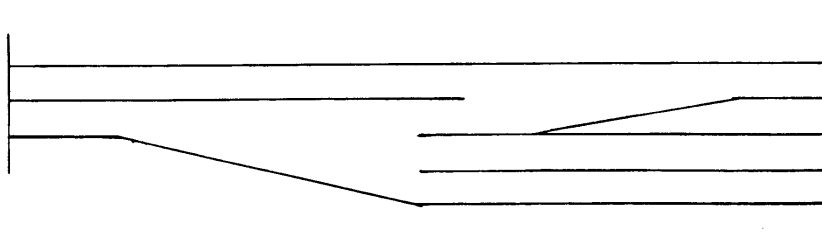

Add a "dump" lane

ALTERNATE LAYOUT

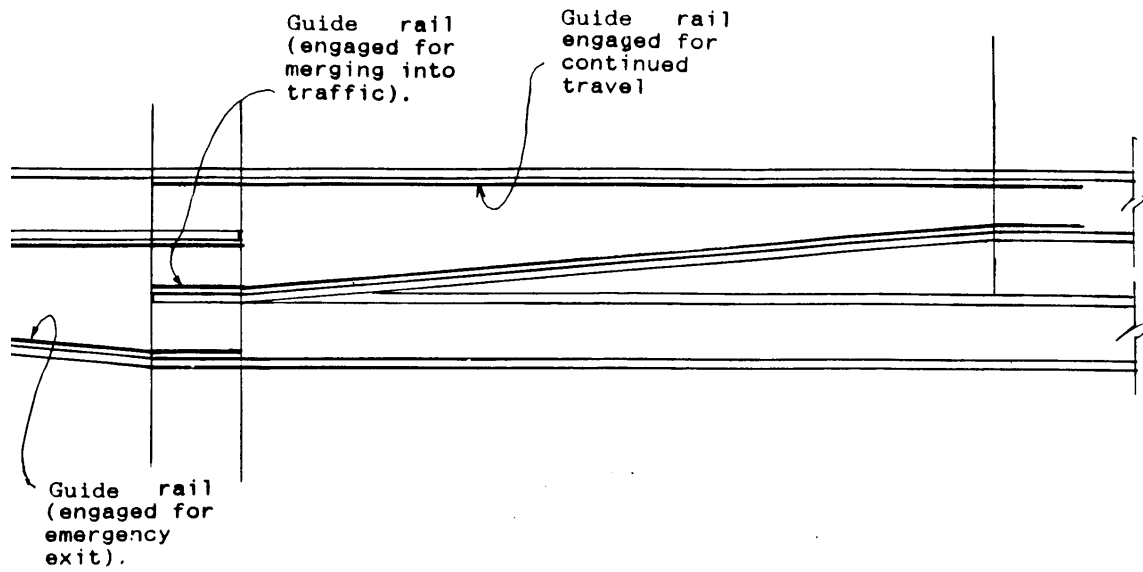

SCHEMATIC PLAN OF ACCESS RAMP (RIGHT HALF)

Scale: 1/8" = 1'-0"

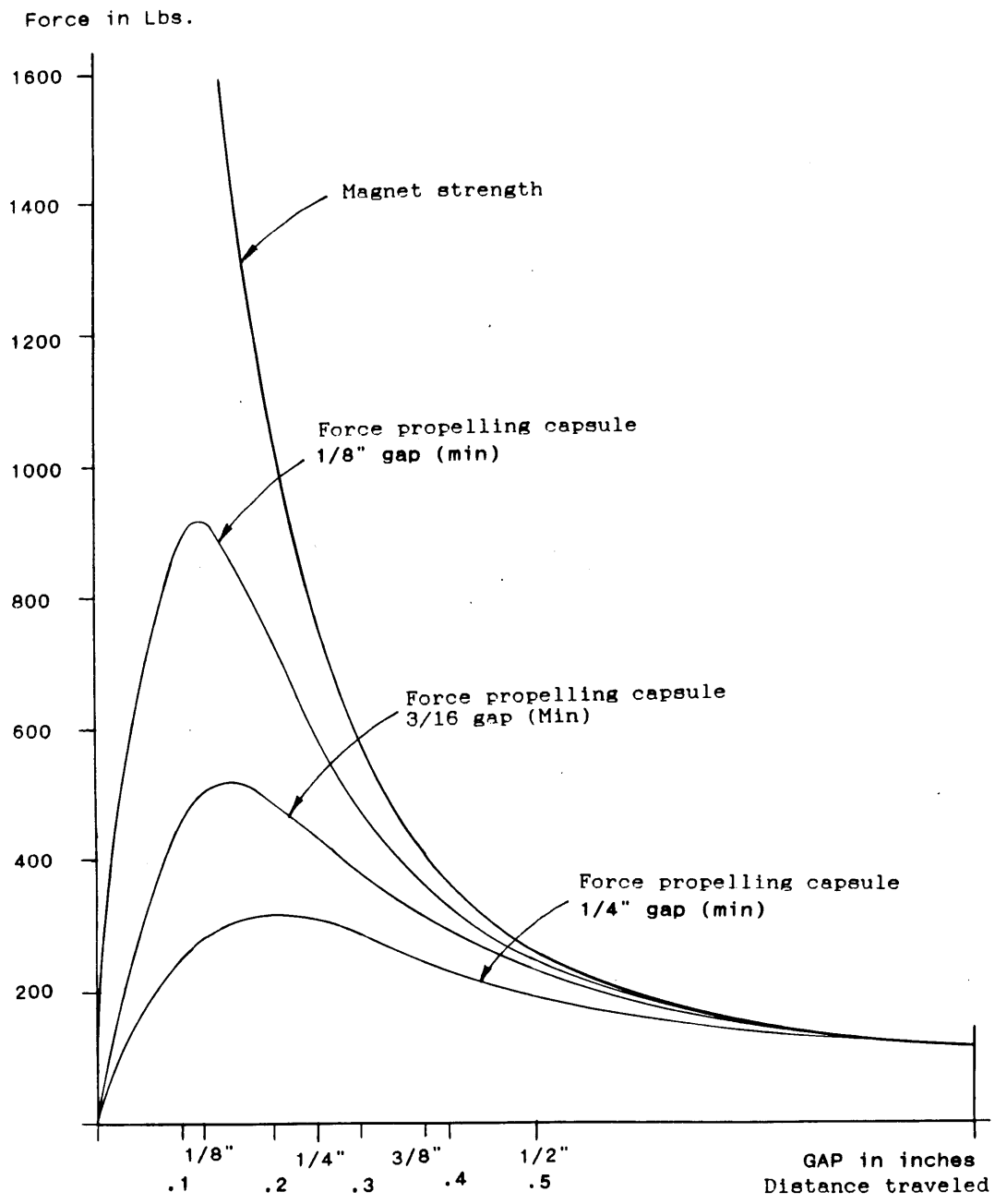

BASIC UNIT ENERGY INPUT

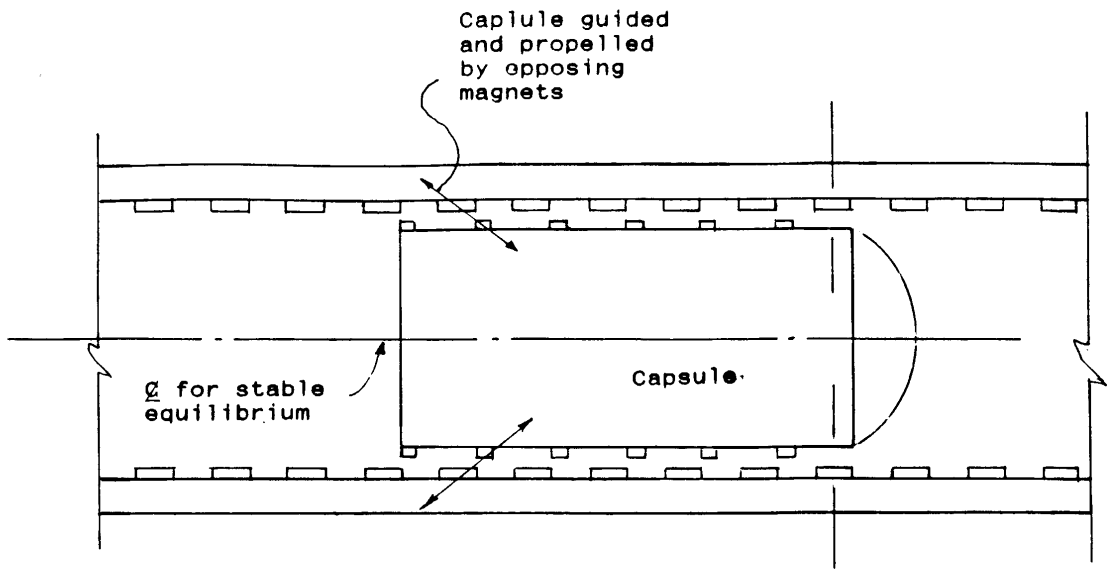

STABILITY AND PROPULSION
PLAN OF MODULE IN TYPICAL GUIDEWAY

(Showing magnet interface)

Scale: 1/2" = 1'-0"

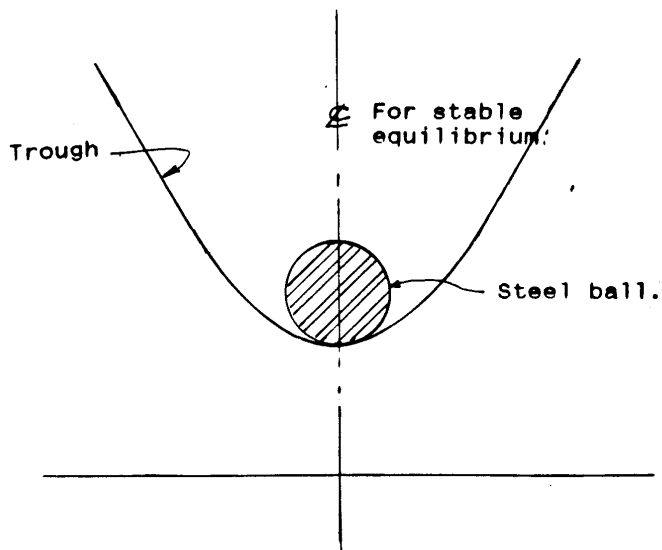

EQUIVALENT MECHANICAL MODEL

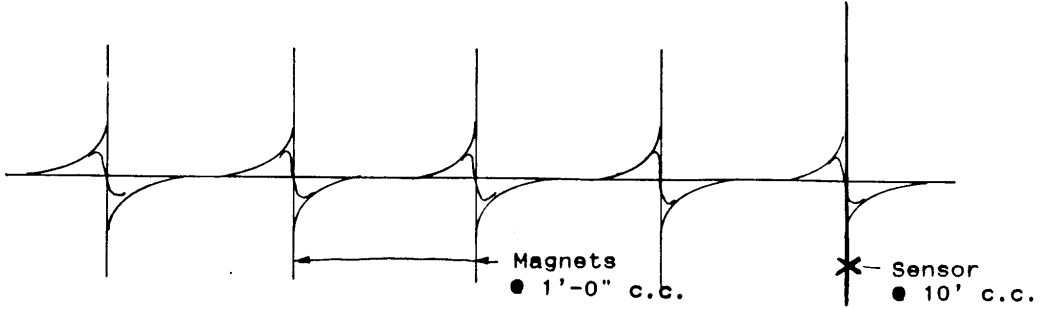

ARRANGEMENT OF MAGNETS AND SENSORS

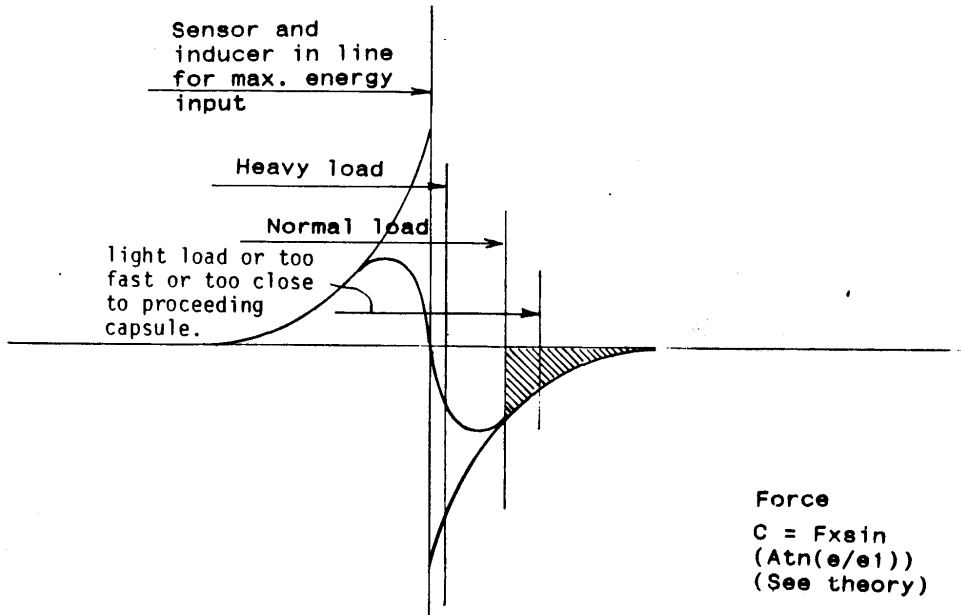

STABILITY AND PROPULSION

Normal Travel Sequence

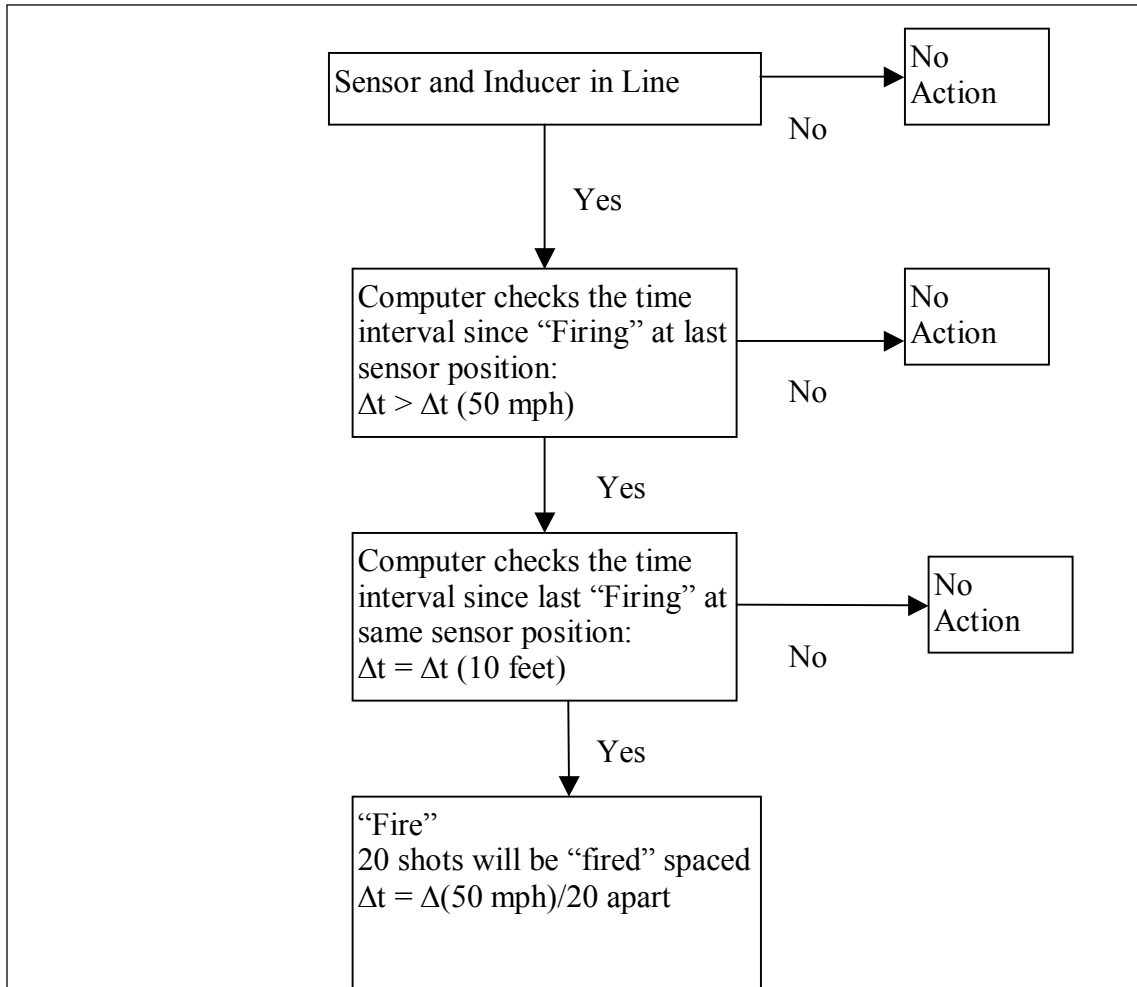

Table 1

Normally, the resistive load of wind, air drag, and rolling friction will be light, and the energy input will be greater than needed. The transportation module will arrive ahead of time and $\Delta t \ll t$ (50 mph). The "firing" will be delayed and the module will have passed the optimum relative position where fired. (See Figure ??).

For a heavier load, $\Delta t < \Delta t$ (50 mph) and firing takes place a fraction of a second after the sensor is lined up with the inducer (Figure 33). For heaving load the system "fires" at the instant the sensor is in line with the inducer ($\Delta t = \Delta t$ (50 mph)).

The only exception to this is if the module is too close to the preceding capsule. In this situation, ($\Delta t < \Delta t$ (10 feet)), the "firing" is therefore delayed and the module eases back because of smaller energy input, falling behind the preceding module.

Entry Sequence

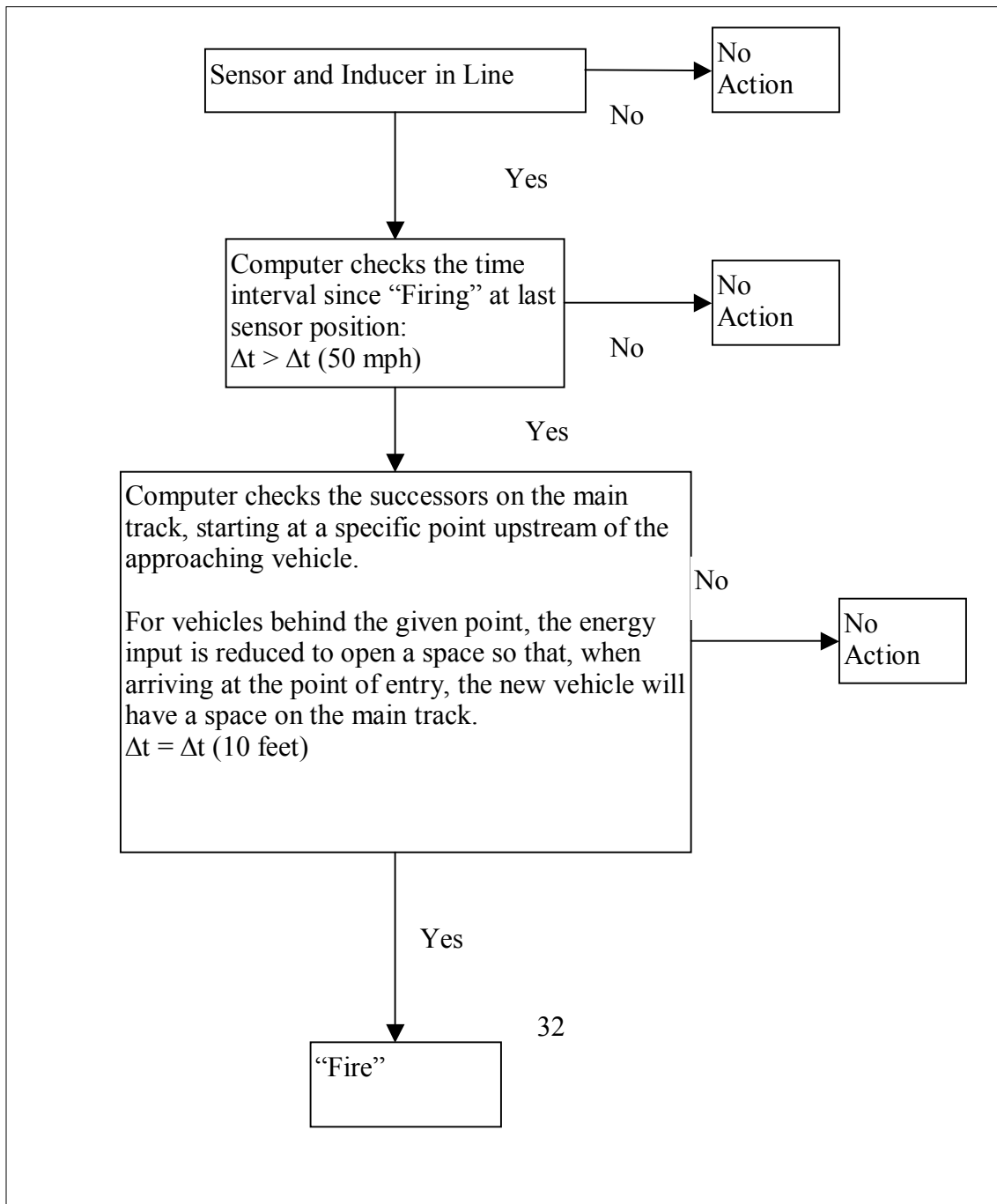

At the last sensor location the computer checks two items:

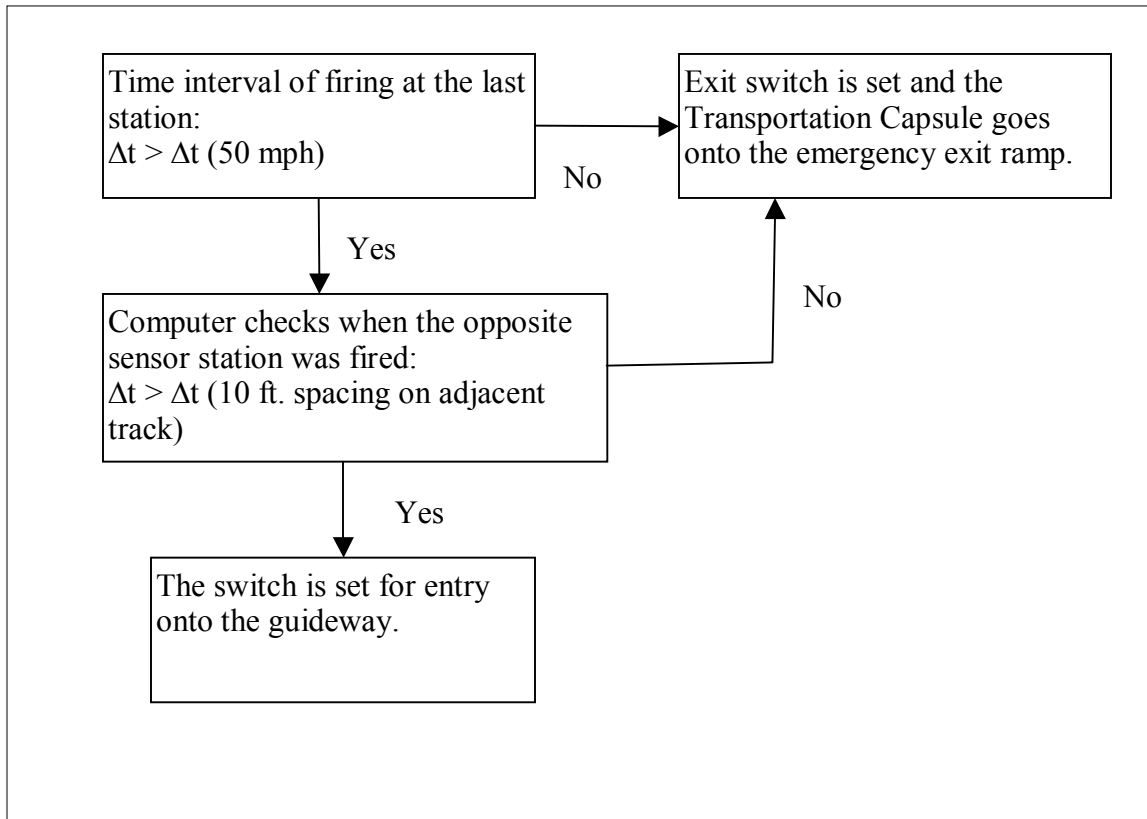

Exit Control

This is a mechanical switch activated manually or by a computer activating and an electromagnetic solenoid switch.

Accident Control

If an emergency should occur, the system is deactivated and all transportation modules come to a stop.

3.1.5 Reliability, Availability and Maintainability Analysis

At the entrance the module is checked for speed and spacing while in the acceleration lane. If the module fails this test, it is rerouted onto an emergency exit lane and returned to the parking lot. If the module should experience a breakdown while on the guideway, this is recognized by the sensors. If firing does not take place within double of the expected time interval, the entire guideway system shuts down. As power for the electromagnets is cut off, the air pressure in the spring loaded pneumatic cylinders is lowered and the tractors touch the ground and provide braking for the modules.

At the location of the disabled module, two alternatives are possible. First, if access to an exit ramp is open, the modules on the guideway may proceed down the ramp. Second, if this mode of exit is not available or desirable, a signal may be sent to the closest station to have a crane commissioned to remove the stalled modules from the guideway. With the module weight of 1000 lbs, the total can be handled by a small crane.

If the guideway is intact, an emergency repair unit may attempt to clear the guideway. Once the repair is completed, the traffic will be restarted. If a major breakdown prevails with no immediate repair possible, the entire guideway system will be emptied. By having each module proceed under its own tractor power to the closest exit ramp.

3.1.6 Facility Design

Station areas consist of access ramps with acceleration lanes and exit ramps with stopping areas. The stopping areas are located at the end of guideway branches. The number of branches and stopping areas is a function of the headway expected at the various stations. For example, the headway of five seconds requires two branches to provide a ten second time interval for slowing down, stopping, and getting off at the stopping area. For exit headway of 1.6 seconds eight branches are needed to allow the same 10 headway at the exit area. A headway of 0.6 seconds requires sixteen branches, and for saturated traffic (one vehicle every 0.14 seconds), a total of 72 branches are required (Figures 24 and 26).

The exit areas are designed to funnel successive modules into alternating sets of branches. The modules are designed to drop onto their tractors as the speed reduces below 30 MPH.

Ticket booths possess computerized check points. Modules are checked for dimensional and functional compliance and adequacy of the various systems, before allowing the module to proceed to the entrance ramps. If found inadequate, the module is steered onto an exit lane and returned to the repair shop for full inspection.

3.1.7 Safety, Personal Security, and System Failure Management Strategies

When traveling over land, a person who otherwise would be exposed to the elements and possible crime, will have a safe escape into the module. It threatened the occupant would send signals or make phone calls to other parties capable of intervening.

For travel on the guideways, the security of the passenger is insured by providing each traveler with his own module. For safety against malfunctioning and system failure, see Management Strategies section 3.1.5.

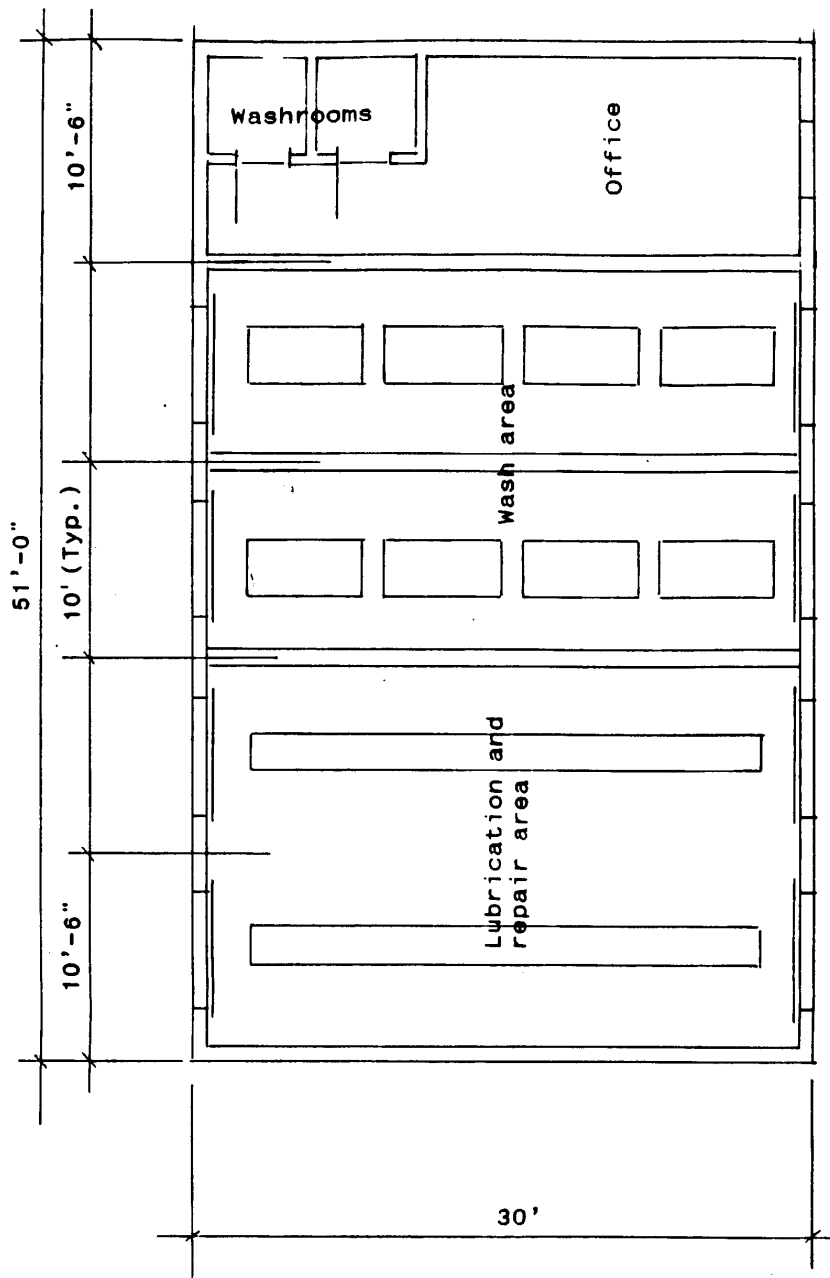

WASH, LUBE AND REPAIR SHOP

SCALE: 1/8" = 1'-0"

Figure 24

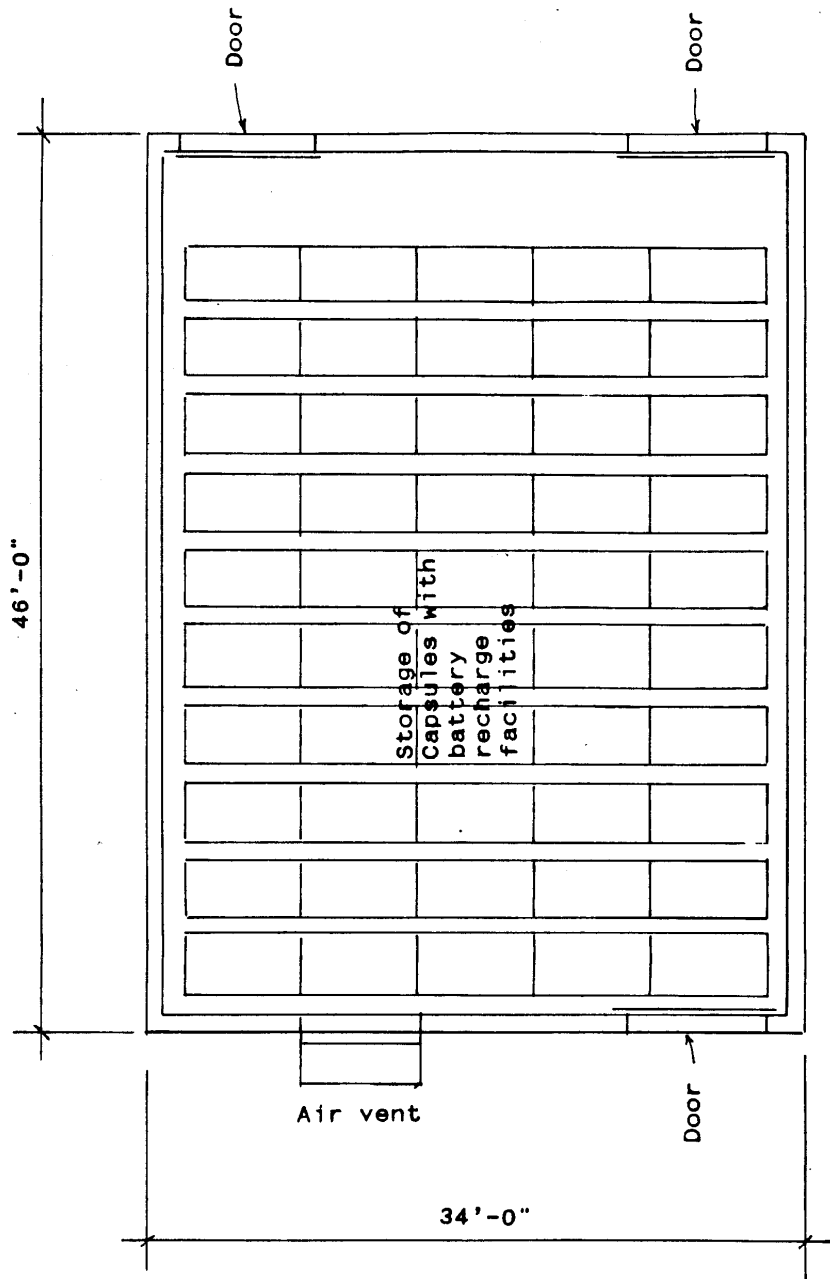

50 UNIT STORAGE FACILITIES

SCALE: 1/8" = 1'-0"

Task 2 Site Specific Design

3.2.1 Composite Site Definition

For this work, we will need the following information from RTA:

1. Maps outlining start to finish (point to point to be serviced).
2. Traffic volume with peak loads.
3. Utility policies for the different sites and utility maps.
4. Zoning restrictions concerning overhead structures, setbacks, beautification of structures, existing parking facilities, existing traffic patterns at station areas, soil borings throughout the guideway lineage, cost of electric power and availability, cost of requisition of private properties.

We expect constraints concerning lineage (layout), minimum radius, encroachment on private properties, our legal rights, etc. We will attempt to work with heavy super elevations and minimum radius.

3.2.2 Network Layout

Plan and profiles will be prepared with RTA approval.

3.2.3 Operation Plan

Vehicle flow chart for a 24-hour typical work day will be prepared, describing individual, group and goods movements.

Task 3 Urban Design

A desirable transportation system is free from noise, creates no pollution, and is pleasing to the eye. To make this possible the guideways are made of pre-stressed concrete, long span girders and tall single pylons with curved members. The single passenger module is lightweight small dimension, electrically propelled, and furnished with rubber wheel supports

Task 4

Simulation

3.4.1 System Simulation

Normal and abnormal operation will be simulated. This will be done using computer simulation in a perspective view of the guideway.

3.4.2 Station Simulation

Flow of vehicles at the station will be simulated using equipment as described in 3.4.1.

3.4.3 Switch and Merge Simulation

Switches and merging details will be demonstrated through drawings and computer illustrations.

Task 5 Communication with Public, Mockups/Models

3.5.1 Station Mock-up/Model

A 1/50 scale model of a typical station will be presented.

3.5.2 Guideway/Vehicle Mock-up/Model

A 1/10 scale model of the vehicle with bogie and switch will be presented.

Task 6

Public Presentation Report

Up to five public presentations will be made by Kolbjorn Saether in the Chicago area in conjunction with RTA representatives.

Task 7 System Development and Deployment Planning

3.7.1 Planning

Design and test plans will be made for

- Each major system element
- Each major subsystem
- Each major component
- Total system

Tests will be performed in-house or by outside testing labs to whatever degree is deemed necessary to assure a successful system.

3.7.2 Cost Estimates, Resource Requirements and Schedules

These will be prepared in form of text, drawings, schedules and budgets.

Task 8 Planning

3.8.1 Phase II Planning

Rough cost estimates for site implementation of the demonstration system are prepared in form of text, schedules, capital/operating and maintenance cost estimates.

Appendix

Future Development

Future development for the use of modules consists of truck, train, and airplane transportation platforms. These are multilevel platforms capable of accommodating many months. They are operated by professional drivers and pilots, following predetermined time schedules for charter for specific trips. The loading of modules takes place at designated loading points located along highways, or eight stations and airports.

The transportation truck platforms and loading ramps are to be maintained by the RTA and will follow schedules similar to those of bus and train services.

These facilities are aimed at the businessmen and businesswomen who can use the extra travel time to expand their work days. Schedules are commuter oriented to allow for morning and evening rush hour traffic.

Intercity travel is more effectively performed with flatbeds hooked to high speed trains. For those we need a modification of the present railroad cars. Travelers move through a 4ft. aisle to either the diner or to washrooms located elsewhere on the train. For overnight travel the seat converts to a sleeping couch, giving the traveler complete privacy.

The next and final phase is transportation using the airplane platforms. At the airport a module will proceed to the airline under its own power, carrying all luggages within the module. Here the tractor will drop it off, and the vehicle will proceed under gravity forces down the loading ramp into the airplane. Similar to train and truck platforms, they are placed in several levels within the cargo space of the airplane. Common facilities, such as washrooms, are accessible through the aisles on the side and between the rows of vehicles. At the destination, the vehicle will roll out of the airplane, propelled by gravity forces, pick up a new, fully-charged tractor unit, and proceed as before, either under its own power or on one of the various ground traffic platforms.

The chart shown in Figure 49 indicates the various transportation phases. It shows how the PTM (Personal Transportation Module) gives the traveler full protection and accommodation from point of departure to point of destination. The module initially moves the traveling through local neighborhoods self-propelled at low speeds.

On high volume guideways, the traveler moves in the module, at moderately high speeds, to distant points within the community and to adjacent communities. Guideway loops are tied to truck and train routes at specific stations where the traveler may enter with the module in a 'piggy-back' high-speed ride to other cities.

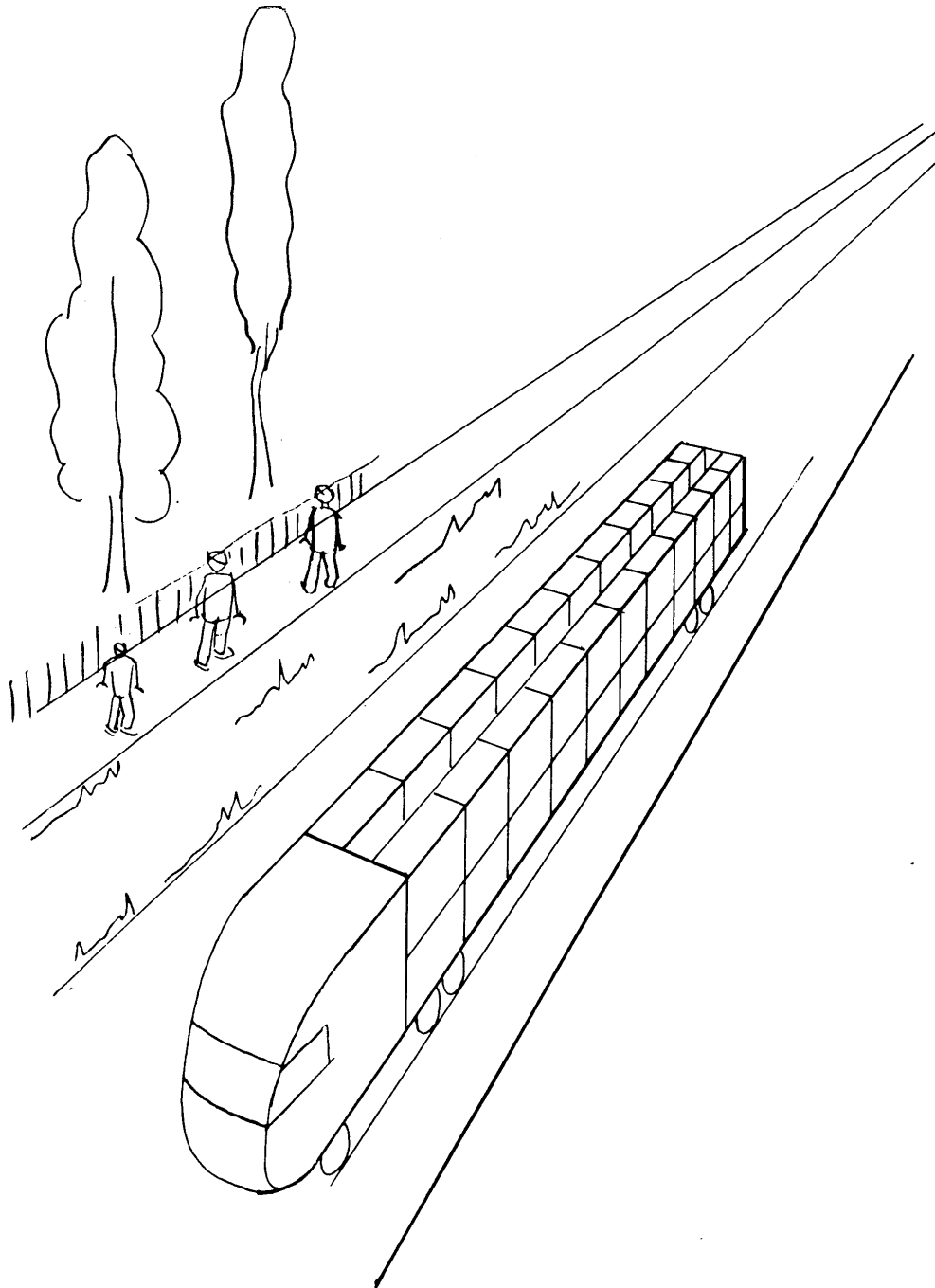

PTM ON BUS PLATFORMS

(V = 65 MPH)

This mode may eventually include airplane trips to distant cities or other countries. The final journey from the airport or guideway is again with the self-propelled module at low speeds.

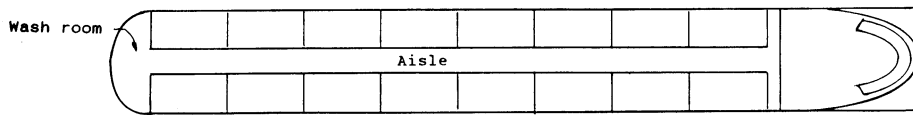
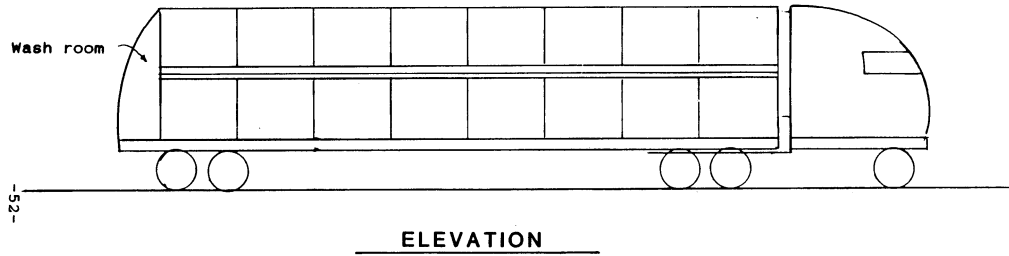

PLAN OF 32 UNIT BUS PLATFORM

The motto is, "Travel with safety and convenience, but first and foremost in comfort."

Fi

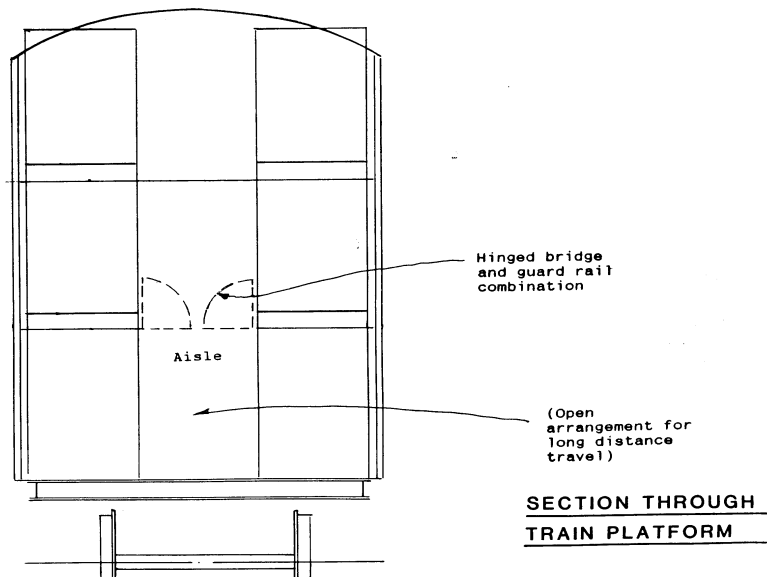

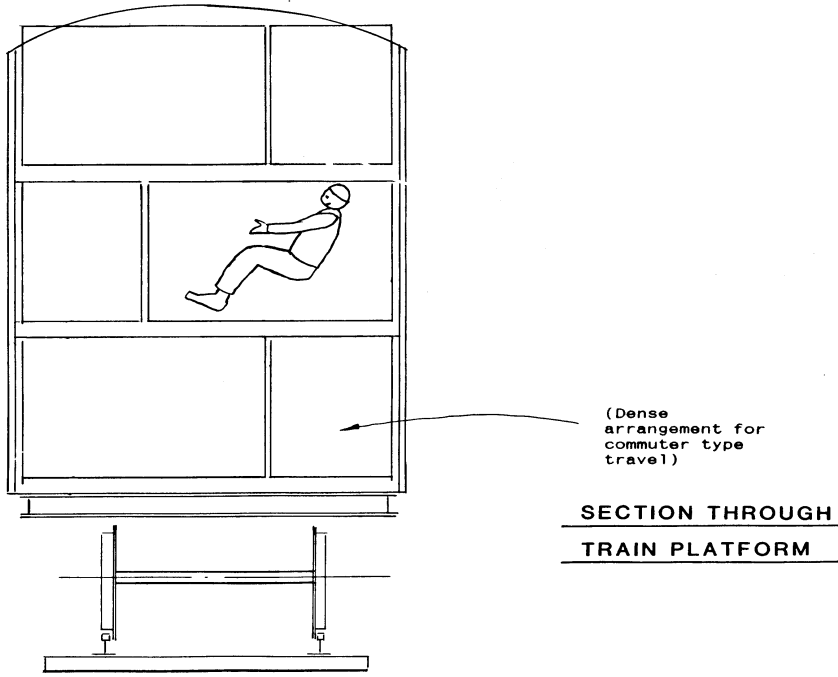
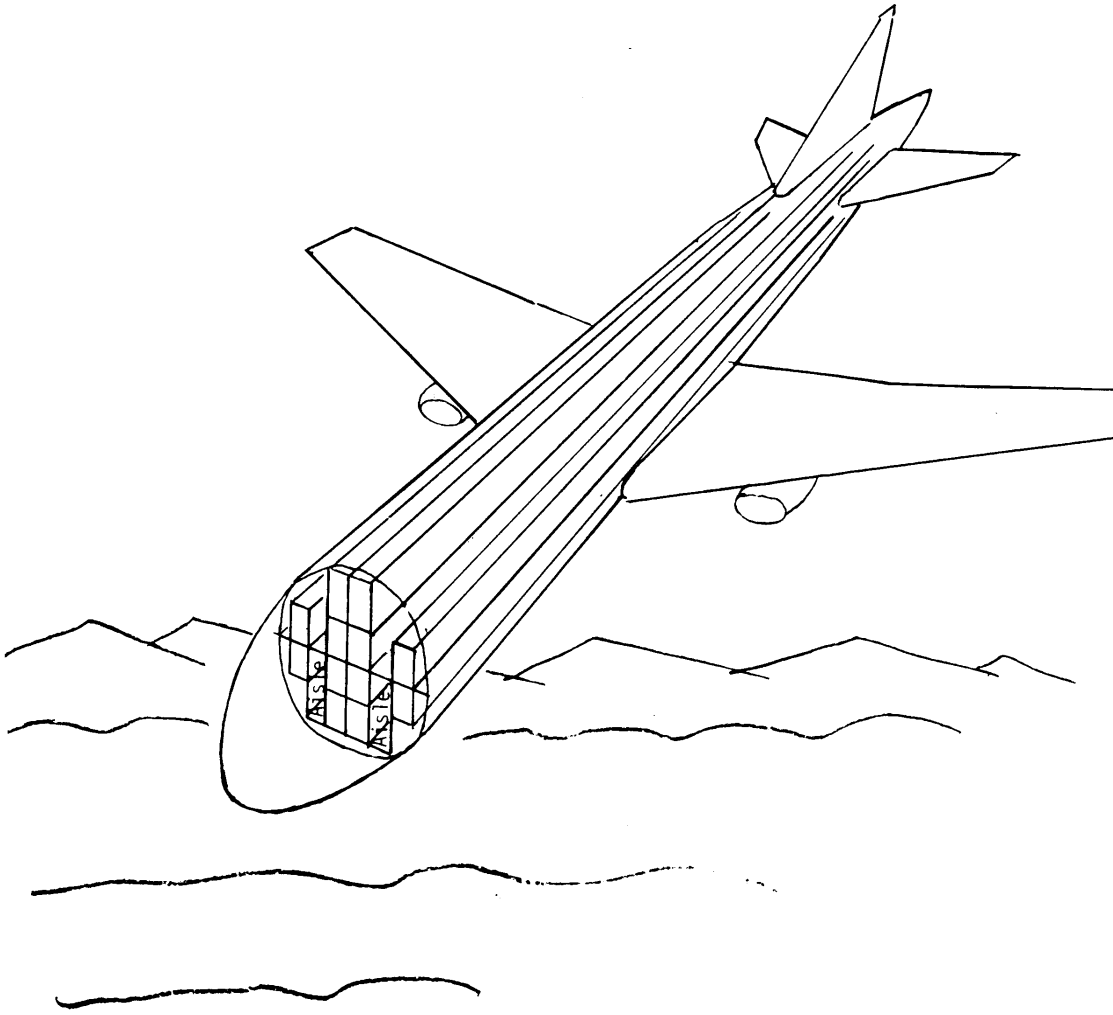
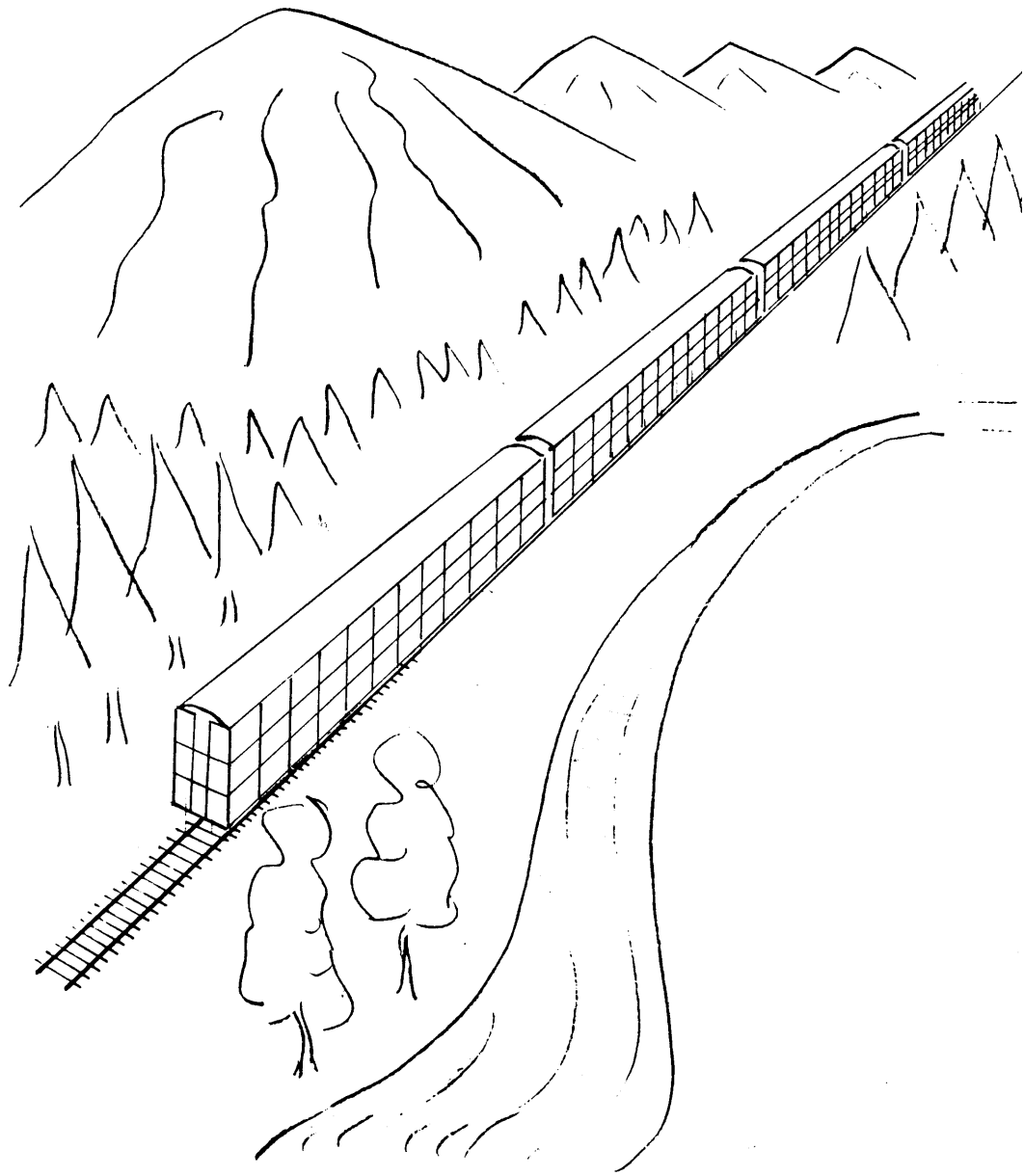

Figure 33



PTM ON AIRPLANE PLATFORMS

(V = 600 MPH)



PTM ON TRAIN PLATFORMS

(V = 300 MPH)

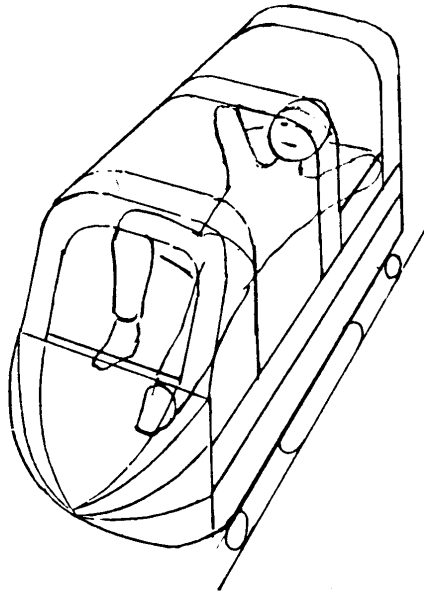

PTM. ALL IN THE COMFORT
OF YOUR PERSONALIZED ENVIRONMENT

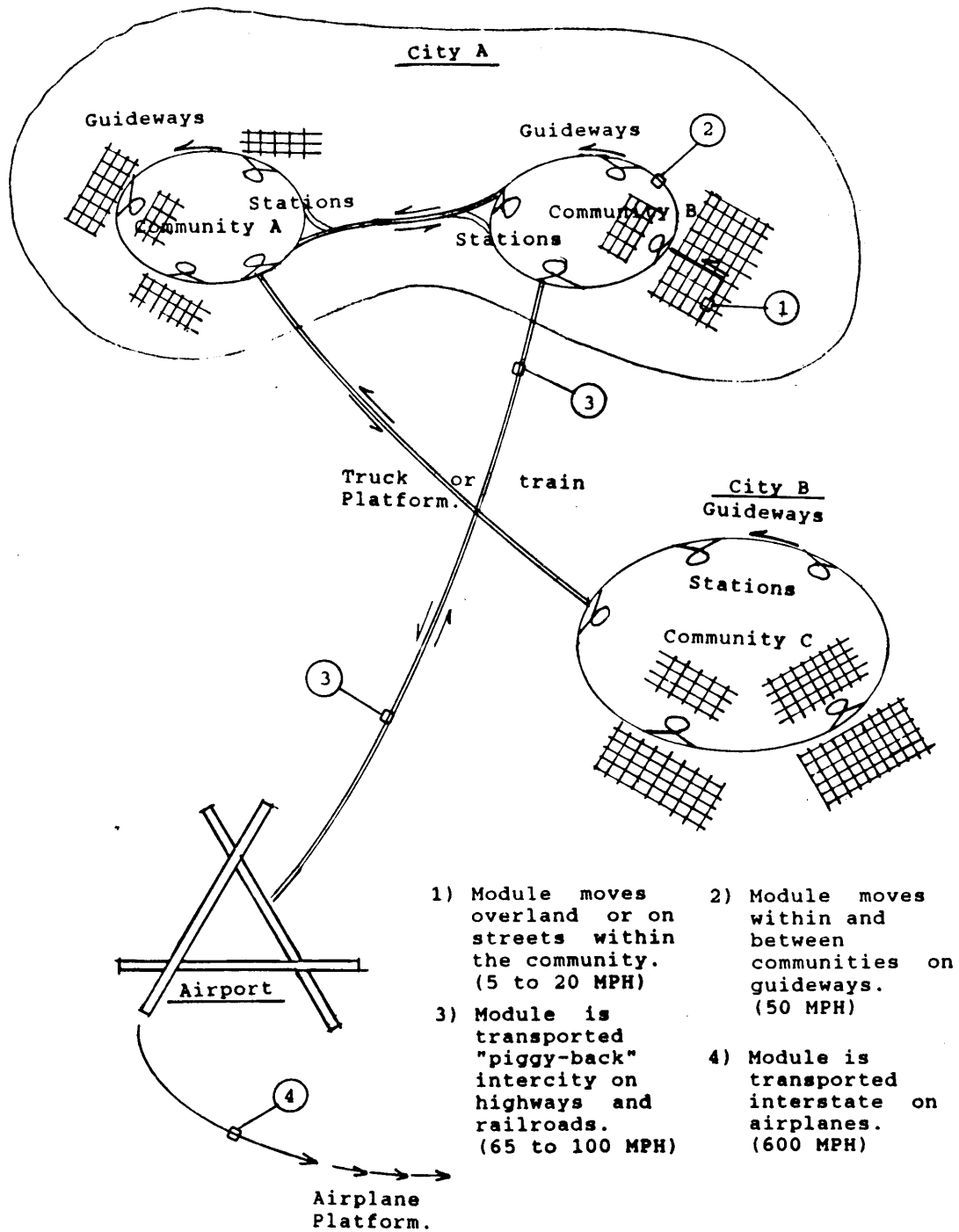

- 1) Module moves overland or on streets within the community. (5 to 20 MPH)
- 2) Module moves within and between communities on guideways. (50 MPH)
- 3) Module is transported "piggy-back" intercity on highways and railroads. (65 to 100 MPH)
- 4) Module is transported interstate on airplanes. (600 MPH)

COMPLETE TRAFFIC "OVERHAUL."

(No Scale)